

---

# SANITATION VALUE CHAIN

Vol.4 No.1

March 2020

## CONTENTS

**Special Issue**  
**Technologies for Making Sanitation Value Chain**

Preface  
.....Ito, R. 002

**Original Articles:**

Challenges and Potentials of Ecological Sanitation: Experiences from the Cases in Vietnam and Malawi  
.....Harada, H. and Fujii, S. 003

Development of Separation Process of Soluble Nutrients from Synthetic Dairy Slurry by Modified Solvay Process  
.....Fujioka, M. and Ito, R. 017

Polyethylene Glycol-Coated Magnetic Nanoparticles-Based Draw Solution for Forward Osmosis  
.....Guizani, M., Endo, T., Ito, R. and Funamizu, N. 027

**Research Report:**

Knowledge, Attitudes and Practices of Sanitation and Hygiene among Primary School Students in Rural Area of Northeast China  
.....He, J., Zeng, Y., Hao, M. and Yamauchi, T. 039

## Special Issue

# Technologies for Making Sanitation Value Chain

## Preface

Sanitation is one of the most important topics included in Sustainable Developing Goals (SDGs), while many actors pay for a lot of effort for solving it. The SDGs report 2018 showed that only about 40% of people in the world can access to safely managed sanitation systems. Moreover, 2.3 billion people especially in South Asia, Oceania, and Sub-Sahara Africa, lacked even basic sanitation that only remove excreta from living spaces, and 892 million people continued practicing open defecation. The report also requires more financial resources and technical capacity to develop sustainable capital infrastructure. Thus, it is necessary to present sanitation attractive for increasing investment from the private sector. The discussions relating to an evaluation of the value of sanitation for all actors and the development of the chain of value are major goals of the Sanitation Value Chain.

This special issue contains three original articles to introduce insights of evaluation of peoples' acceptance of fecal compost for agricultural application via composting toilet, a proposal of new production system for excreta-based fertilizer, and the latest elemental technology for sustainable membrane treatment.

We sincerely hope that this issue on the technical aspects of the Sanitation Value Chain can benefits researchers and actors working on the challenging topics of solving sanitation problems. We would like to appreciate all authors who contributed peer-reviewed articles to this special issue. We also thank the great support of the editorial staff of the *Sanitation Value Chain*.

Guest editor

**Ryusei ITO\***

\* Faculty of Engineering, Hokkaido University, Japan

# Challenges and Potentials of Ecological Sanitation: Experiences from the Cases in Vietnam and Malawi

Hidenori HARADA<sup>1</sup> and Shigeo FUJII<sup>1</sup>

<sup>1</sup> Graduate School of Global Environmental Studies, Kyoto University, Japan

## Abstract

The world's sanitation systems must be up to the challenge of addressing the global crises of water shortages and food insecurity in the face of a growing population. To help address these problems, ecological sanitation (Ecosan), which typically involve the use of urine-diverting dry toilets (UDDTs) and the application of excreta in agriculture, can be employed. This paper discusses the challenges and potentials of the Ecosan approach in terms of 3 essential requirements—continuous defecation use, reduction of health risk, and use of excreta—by examining 3 cases of Ecosan use in Vietnam and Malawi. The experience with traditional Ecosan in rural Vietnam suggests that dry sanitation practices that apply Ecosan are effective at reducing fecal contamination in the surrounding water environment, thereby reducing the health risk from unavoidable accidental ingestion of contaminants. However, current sanitization processes involving the application of manure to agricultural products represent a significant health risk challenge. The experience with modern UDDTs in rural Vietnam suggests that they can be continuously used for defecation for long periods of time without intervention, while there remain major challenges to continuous use from physical damage to the UDDT structures. The proper management of fecal chambers can successfully control the offensive odors that are a source of wide concern. In rural Malawi, the introduction of modern UDDTs successfully fostered a demand for the use of feces by raising the perception of its value in agriculture and through an integration of the Ecosan project into an agricultural technology transfer program. Urine use, by contrast, did not gain a wide acceptance, suggesting that raising an awareness of the effects of urine on agriculture is a key challenge. Thus, although some challenges still need to be overcome, 3 cases of Ecosan showed bright potentials of the Ecosan approach from the 3 essential requirements.

*Keywords: ecological sanitation, urine-diverting dry toilets, agriculture, health risk, Vietnam, Malawi*

## Introduction

Securing proper sanitation is vital to human health and dignity. Unfortunately, 2.3 billion people worldwide still lack access to basic sanitation services (WHO and UNICEF 2017). The United Nations' Sustainable Development Goals include water and sanitation targets of securing adequate sanitation for all by 2030<sup>1)</sup>. However, there are at present no ideal solutions to ensuring global sanitation.

Future sanitation solutions should also be compatible with solutions to the challenges of water shortage and food insecurity. This provides an opportunity for the implementation of sanitation approaches that utilize dry sanitation and the use of excreta with agriculture. Such approaches include ecological sanitation (Ecosan), which has been promoted for several decades (Esrey et al. 1998; Jonsson et al. 2004; Winblad and Simpson-Hébert

---

1) 70/1. Resolution adopted by the General Assembly on 25 September 2015, "Transforming our World: The 2030 Agenda on Sustainable Development", United Nations, 21 October 2015. [https://www.un.org/en/development/desa/population/migration/generalassembly/docs/globalcompact/A\\_RES\\_70\\_1\\_E.pdf](https://www.un.org/en/development/desa/population/migration/generalassembly/docs/globalcompact/A_RES_70_1_E.pdf) (Accessed July 4, 2019).

2004; Werner et al. 2009). According to Winblad and Simpson-Hébert (2004), “[e]cological sanitation is based on three fundamental principles: preventing pollution rather than attempting to control it after we pollute; sanitizing the urine and the feces; and using the safe products for agricultural purposes.” Ecosan is typically implemented through the use of urine-diverting dry toilets (UDDTs), which do not use water and separate nutrient-rich urine from physically harmful feces to enable the use of the separated urine and sanitized feces for agriculture.

Although many projects following the Ecosan approach have been implemented in developing countries, some have faced challenges in the initial acceptance of UDDT installation and in the continuous management of the UDDTs following installation (Drangert 2004; Jackson 2005; Uddin et al. 2014). Regardless of type, there are two essential toilet requirements: to provide a comfortable defecation space that can be continuously used (i.e., continuous defecation use); and to reduce health risk through toilet use (i.e., health risk reduction). Toilets using the Ecosan approach must meet these requirements and, unlike ordinary toilets such as water flush units or pit latrines, must be able to separate out human excreta for agriculture (i.e., excreta use). Typically, urine is used as liquid fertilizer while sanitized feces are used as manure for crops. Accordingly, a major challenge to the use of Ecosan is fecophobic attitudes reflecting a dislike of the use of excreta for agriculture.

This paper aimed to examine the challenges and potentials of Ecosan in terms of 3 essential requirements: continuous defecation use, health risk reduction, and excreta use. For this purpose, we re-examined 3 cases of Ecosan use in Vietnam and Malawi with which the authors were previously involved. The first case involves traditional Ecosan practices at a rural community in northern Vietnam in which traditional dry sanitation, including the use of UDDTs and the application of excreta to agriculture (Harada et al. 2016; Julian et al. 2018) was practiced. This case is used to discuss the health risk from fecal exposure through the long-term use of Ecosan. The second case involves the introduction by an NGO of UDDTs to a rural community in southern Vietnam in which excreta had not previously been used for agricultural (Harada et al. 2004a, b). This case is used to examine how the long-term use of modern UDDTs affects continuous defecation use. The final case involves the introduction of similarly designed UDDTs in rural Malawi by the same NGO, a project that was successfully scaled up (Harada et al. 2018). This case is compared with the preceding case in Vietnam to examine the use of excreta. Finally, the challenges and potentials of Ecosan are examined based on the experiences obtained from the 3 cases.

## 1. Methodology

### 1.1. Case study A: Assessment of fecal exposure through traditional ecosan practices

#### Study area

The study area was located in northern Vietnam (Trai hamlet, Van Tu commune, Phu Xuyen district, Hanoi city; Figure 1). The area has a history of toilet use and the agricultural application of excreta (Pham et al. 2015; 2017). Farming is a major occupation and, in the past, most residents engaged in fishery in a nearby river to obtain supplemental income. As a result of recent industrialization and urbanization processes, however, the river has become seriously polluted and many people have stopped fishing. General information on the hamlet is given in Table 1.

As of 2010, 56% of the households in the study area employed dry toilets (Figure 2), which treat excreta using drying agents such as ash and dry soils. Following several months retention in a toilet chamber, the resulting fecal mixture is used for agriculture. Some dry toilets use urine diversion, while others do not. Households with higher economic status tended to use water flush toilets. Through urbanization and industrialization, a large amount of water has been available and house buildings have had modern structure. Accordingly, traditional dry toilets have been gradually replaced by conventional water-flush toilets.

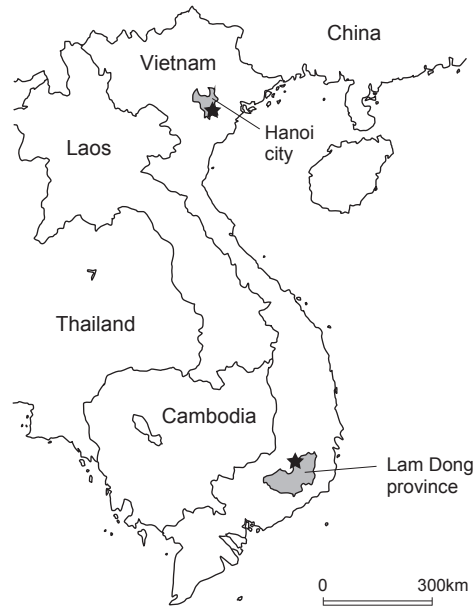

**Figure 1. Project sites: Traditional use of human waste (Phu Xuyen district, Hanoi city); NICCO Ecosan project (Lam Ha district, Lam Dong province).**

**Table 1. Summary of target hamlet statistics.** (Data as of 2010, modified from Pham et al. 2017)

Information	Unit	Data
Population	person	800
Household number	household	240
Total area	ha	56.1
<i>Paddy field</i>	ha	52.6
Household income	USD/month	98–147
Toilet type	-	-
<i>Cistern flush toilet</i>	%	19
<i>Pour flush toilet</i>	%	25
<i>Dry toilet without urine diversion</i>	%	44
<i>Dry toilet with urine diversion</i>	%	12



**Figure 2. Urine diverting dry toilet at the Trai hamlet study site.**  
(Taken by the author)

### Fecal contamination and fecal exposure assessment

Unsanitary conditions allow fecal matter to be emitted to the environment, causing contamination of the living and surrounding environment by fecal microorganisms and the potential exposure, via a number pathways, of humans to fecal pathogens through various fomites or media. Here, we discuss the impact of excreta use on human health in Trai hamlet, where people use dry feces from toilets for agriculture, based on the fecal contamination data and exposure trends in the hamlet uncovered by Harada et al. (2016) and Julian et al. (2018).

We first briefly explain the methodology used to construct and carry out the fecal contamination survey and calculate exposure. Fecal contamination was defined in terms of the concentration of *Escherichia coli* in traditional dry and water flush toilet users for 10 fomites ( $n = 5\text{--}34$ ), including drinking and environmental water, eating utensils, soils, human manure, and environmental water. Fecal exposure for traditional dry toilet users was re-assessed through the eight pathways identified by Harada, et al. (2016): intentional intake of drinking water, unintentional intake of non-drinking water during bathing, irrigation activities, swimming and fishing, unintentional intake of soil during agricultural activities, and unintentional intake from dining equipment such as bowls and chopsticks. *E. coli* was used as the fecal contamination indicator bacteria, with exposure to *E. coli* calculated as follows:

$$Dose_{day} = \sum C_i \times F_{i,j} \times I_j \quad (1)$$

where  $Dose_{day}$  is the *E. coli* dose per day (CFU/day),  $C_i$  is the concentration of *E. coli* in medium  $i$  {CFU/(unit media amount)},  $F_{i,j}$  is the exposure factor, or unit intake amount of medium  $i$  during activity  $j$  {amount/(hour or count)}, and  $I_j$  is the intensity of activity  $j$  {(hour or count)/day}. The exposure factors and activity intensities used in the exposure calculations are listed in Table 2. Probability density functions (PDFs) defined based on survey results are listed in Table 3; using the PDFs, daily exposures to *E. coli* were stochastically estimated based on Monte Carlo simulations.

## 1.2. Case study B: Introduction of UDDTs in rural Vietnam

### Study area

The project site was located at Dan Phuong commune, Lam Ha district, Lam Dong province in the central highlands of Vietnam (Figure 1), which has a tropical monsoon climate. A few households owned unsanitary simple pit latrine without slab, and most households had no toilet. People in the area had never experienced any use of human excreta for agriculture. In 2002, the total population at the project site was 491 across 84 households, of which 67 were ethnic minority families. Most of the households made a living from agriculture. Prior to the project, most of the population practiced open defecation and nearly 80% were infected with intestinal parasites (Kaku et al. 2004). The project site had hosted several community development projects sponsored by the Nippon International Cooperation for Community Development (NICCO), a Japanese NGO. At the request of the local residents, an Ecosan project was conducted by NICCO with the support of Kyoto University faculty (one of whom is an author of this paper) and the Nha Trang Pasteur Institute.

### Project outline

Under the project, 85 UDDTs were introduced during 2012–2013. Eighty-four (one per household) of the UDDTs were introduced for household use and one was installed at a primary school for the use of the resident teachers. Outer and inner views of a UDDT are shown in Figure 3 and 4, respectively. The toilet design was based on UDDTs previously developed in Vietnam (Bui et al. 2001; Nha Trang Pasteur Institute VinaSanres Project

**Table 2. Data used for calculation of daily exposure in the community where people use excreta for agriculture.** (Modified from Harada et al. 2016)

Pathway	Media	Exposure factor	Activity intensity
Intentional intake of drinking and eating			
<i>Eating</i>	Raw vegetables	70.7 g-wet/day	-
<i>Drinking</i>	Boiled-and-stored rainwater	liter/day	-
Unintentional intake of water			
<i>Bathing</i>	Stored well water	0–21 ml/time	1 time/day
<i>Irrigating activities</i>	Irrigation water	0–11.2 ml/hour	8 hour/day
<i>Swimming</i>	Pond water	0–205 ml/hour	1–2 hour/day
<i>Fishing</i>	Pond water	0–11.2 ml/hour	8 hour/day
	River water	0–15.3 ml/hour	3 hour/day
Unintentional intake of soil			
<i>Farming</i>	Rice field soil	1–10 g/day	-
Unintentional intake during eating			
<i>Using devices of eating</i>	Bowl	All surface	3 time/day
	Chopsticks	All surface	3 time/day

**Table 3. Probability density functions for drinking water consumption and *E. coli* concentration in each medium.** (Modified from Harada et al. 2016)

Item	Distribution type	Parameter
Drinking water consumption (liter/day)	Lognormal	$\mu=1.15 \times 10^0$ , $\sigma=5.60 \times 10^{-1}$
<i>E. coli</i> conc. in drinking water (CFU/100 ml)	Lognormal	$\mu=8.79 \times 10^0$ , $\sigma=2.69 \times 10^1$
<i>E. coli</i> conc. in stored well water (CFU/100 ml)	Lognormal	$\mu=3.93 \times 10^3$ , $\sigma=7.55 \times 10^3$
<i>E. coli</i> conc. in irrigation water (CFU/ml)	Lognormal	$\mu=9.10 \times 10^2$ , $\sigma=5.03 \times 10^3$
<i>E. coli</i> conc. in pond water (CFU/ml)	Uniform	min.= $1.26 \times 10^2$ , max= $4.67 \times 10^3$
<i>E. coli</i> conc. in river water (CFU/ml)	Lognormal	$\mu=1.78 \times 10^3$ , $\sigma=2.55 \times 10^3$
<i>E. coli</i> conc. in rice field soil (CFU/g-dry soil)	Lognormal	$\mu=2.60 \times 10^4$ , $\sigma=5.76 \times 10^6$
<i>E. coli</i> count on bowl surface (CFU/bowl)	Lognormal	$\mu=1.44 \times 10^1$ , $\sigma=5.23 \times 10^1$
<i>E. coli</i> count on chopstick surface (CFU/pair)	Lognormal	$\mu=4.97 \times 10^2$ , $\sigma=9.69 \times 10^5$

**Figure 3. UDDT outside views.**  
(Taken by the author)**Figure 4. Inner view of toilet.**  
(Taken by the author)

2002) and partly modified for the project. The UDDTs were constructed by local builders trained and supervised by NICCO; beneficiaries partly contributed the construction by providing labor.

The toilets employed a urine-diverting squatting pan with 2 covered and separated fecal chambers on each side. Urine deposited into a small hole between the chamber covers was piped to a urine container located behind the toilet building, while ash was mixed with feces deposited in the chambers for sanitization. The deposited feces were removed through small doors at the backside of the toilet following an appropriate retention period, which was determined to be at least 10 months based on an associated ascaris eggs inactivation experiment (Harada et al. 2006). After dilution, urine deposited in the container was used as liquid fertilizer for agriculture.

For the project structure, before conducting this Ecosan project, NICCO had conducted organic farming education activities in the same area, and later on started this Ecosan project together with the organic farming education activities. However, due to political reasons, NICCO faced a difficulty to continue the activities at the early timing of this Ecosan project. Finally, the organic farming education activities had been suspended and the Ecosan toilet project had been solely conducted.

Prior to construction of the toilets, orientation and lecture series were provided. Once use had begun, house-to-house instructions were provided to each household every 2 to 3 weeks for 4 months by a female local health worker who was also a beneficiary of the Ecosan project and a user of the UDDT. For further details on the project, refer to Harada et al. (2004a, b).

#### House-to-house survey on toilet management and user reactions

For our analysis, we used the monitoring results of UDDT operation from Harada, et al. (2004b) and Harada et al. (2009). During months 0–4 following installation, repeated house-to-house monitoring surveys were conducted. The surveys used true-or-false check sheets to assess 17 items related to toilet use and management conditions. From months 7–38, project members were barred from entering the village for political reasons, precluding any monitoring or intervention efforts during this period. Nearly 3 years later, at month 39, one of the authors was able to re-enter the village and conducted a post-intervention monitoring survey comprising structured interviews and observations on construction status, toilet management, and use.

### **1.3. Case study C: UDDT introduction project in rural Malawi**

#### Study Area

Malawi is a landlocked country in southeast Africa that is separated from Tanzania and Mozambique by Lake Malawi, to which surface and ground water are collected from the west bank (Figure 5). Rural communities in the country face continued threat of famine as a result of poor infrastructure that hinders economic growth. Nevertheless, as of 2017, only 24.7% of Malawi's rural population did not have at least basic sanitation services (WHO and UNICEF 2019).

#### Project outline

Following their experience with the introduction of Ecosan in Vietnam, NICCO implemented a comprehensive rural development project starting in 2007 in 3 districts of Malawi (Nkhotakota, Dowa, and Lilongwe, shown in Figure 5). The UDDT design was based on that of the UDDTs introduced in Vietnam by NICCO, but with some modification. In total, 1,052 units were constructed across the 3 districts, including a number of public units (Figure 6). According to NICCO, there were a total of 26,100 beneficiaries. Most of them did not have any access to improved sanitation and had never experienced human excreta use for agriculture.

The UDDTs were constructed by local builders who were trained and supervised by NICCO, with beneficiaries



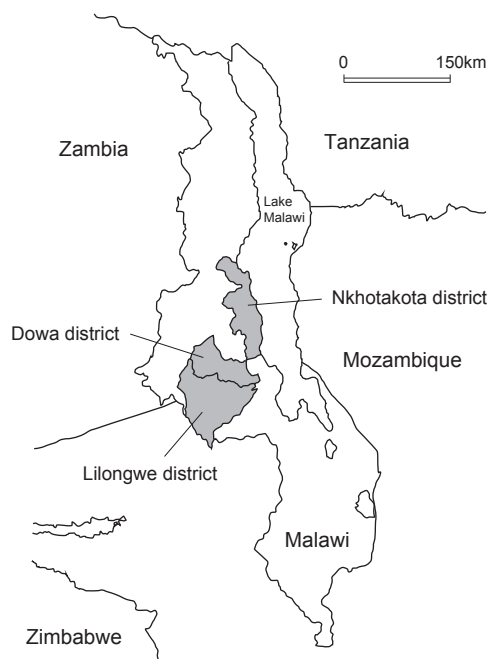

**Figure 5. Location of Ecosan project in Malawi.**



**Figure 6. Ecosan toilet constructed by the NICCO Malawi Ecosan project.**  
(Taken by the author)

partly contributing to the construction by collecting bricks and providing labor. Workshops were organized on how to use the UDDTs, maintain toilet cleanliness, and use collected feces and urine for agriculture. Ash was utilized to sanitize fecal matter and for washing hands with water following toilet use.

For the project structure, differently from NICCO's Ecosan toilet project in Vietnam, this Ecosan project in Malawi was conducted in integrated manner with other various community development activities; the details of which were described in the following results and discussion section. The Malawi Ecosan project itself comprised 3 sub-projects carried out over a total of eight phases from 2007 to 2014 and was of a much larger scale than the project in Vietnam. Although both projects employed similar UDDT designs, the project in Malawi had more success in scaling up and in establishing the use of fecal matter for agriculture. To ascertain the reason for the improved results, the Malawi project reports were analyzed from the perspective of project structures and NICCO personnel were interviewed.

#### Conditions of UDDTs after five years and beyond

Our data on the long-term conditions of the UDDTs installed by the NICCO Malawi Ecosan project were taken from Harada et al. (2018), in which 277 households were interviewed to determine their demographic conditions, the structural status of their UDDTs, the continuous use of urine and feces, and their perceptions of the effects of UDDT use on diarrhea reduction and of feces and urine on yield increase.

## 2. Results and Discussion

### 2.1. Health risk from using excreta for agriculture in rural Vietnam

Figure 7 shows a comparison of the *E. coli* concentration results in the living environment for traditional dry and

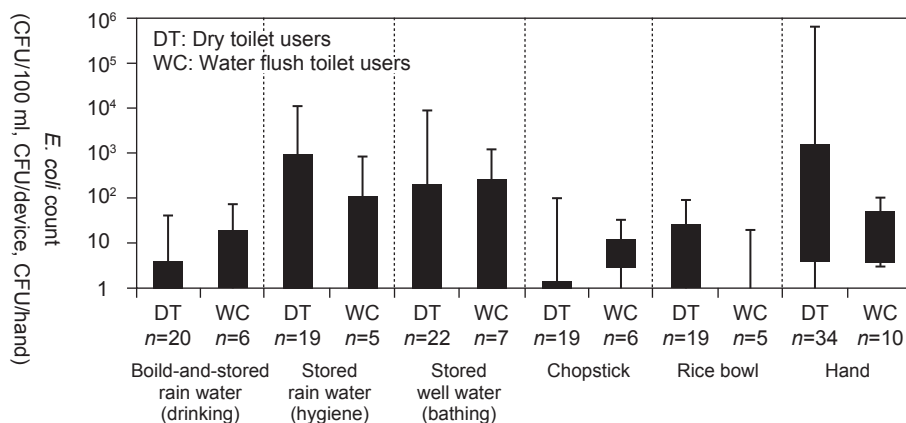

**Figure 7. *E. coli* concentrations in living environments and hands in Vietnam.**

Box plots indicate 1st and 3rd quantile ranges and whisker indicate the maximum and minimum values.

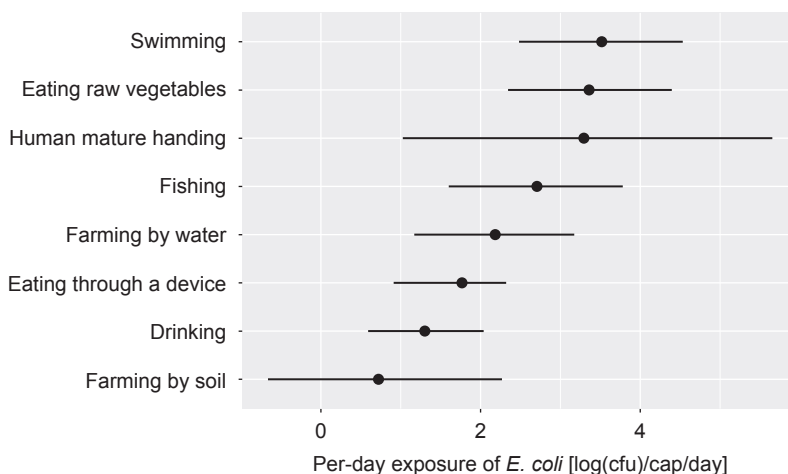

**Figure 8. Daily exposure pathways to *E. coli* in a community using excreta.**

The figure shows 75-percentile ranges and median values.

water flush toilet users. The living environments of both user types were heavily contaminated and posed potential health risks from fecal pathogens. No significant difference in contamination could be found between the 2 user types, indicating that the use of traditional dry toilets did not significantly affect fecal contamination in the highly contaminated living environment.

The exposure patterns in the daily life of the Vietnamese community that uses excreta are shown in Figure 8. Three major pathways of fecal exposures are swimming (12.5<sup>th</sup> percentile–median–87.5<sup>th</sup> percentile: 2.48–3.52–4.53 log[CFU]/cap/day), eating raw vegetables (2.34–3.36–4.39), and human manure handling (1.01–3.30–5.65). These high daily exposures can be respectively attributed to the accidental ingestion of strongly contaminated pond/river water, the consumption of contaminated raw vegetables, and the accidental ingestion of contaminated human manure.

It is notable that the exposures from the pond and river water have the largest pathways, indicating the importance of avoiding the discharge of fecal matter to local water bodies. In the area, 56% of households used dry feces and liquid urine for agriculture, while the other 44% discharged excreta using water-flushed toilets with very limited

**Table 4. Continuity of use of UDDTs with and without serious damage.**  
(Modified from Harada et al. 2009)

Status of toilet construction	Toilet in use		Toilet not in use	
	%	<i>n</i>	%	<i>n</i>
All toilets	65.8	50	34.2	26
<i>Toilet not seriously damaged</i>	83.6	46	16.4	9
<i>Toilet seriously damaged</i>	19.0	4	81.0	17

Note: Four toilets used by families that left the village are excluded.

**Table 5. Proportion of toilets with properly operating fecal chambers.**

Check item	Months 0–4	Month 39
	% of UDDTs in use	% of UDDTs in use
Offensive fecal smell inside toilet rooms	1.3	14.0
Maggots inside fecal chambers	0	12.0
Many flies (> 10) inside fecal chambers	0	0.0

or no treatment.

Unlike water-flushed toilet systems, which pollute the water environment through the dumping of sanitary wastewater, traditional dry toilets do not directly pollute the water environment because they produce no sanitary wastewater beyond urine. However, improperly used dry toilets are associated with exposure through the contamination of raw vegetables and the handling of human manure. Contamination of human manure ( $7.17 \times 10^4$ – $1.27 \times 10^4$ – $2.53 \times 10^6$  CFU/g-wet) as a result of the improper sanitization of human feces in traditional dry toilets is a direct exposure pathway and a major source of raw vegetable contamination.

Thus, improper sanitization of their fecal products can increase the health risk associated with exposure to unsanitary fecal products (i.e., manure) and foods grown with the manure while traditional dry toilets do not discharge fecal wastewater and can be effective at reducing the health risk from exposure to nearby water bodies. Feces extracted from dry toilets can be properly sanitized theoretically; this is, however, not always achieved throughout long-term use. The experience with traditional Ecosan practices in Vietnam suggests that long-term sustainability of sanitization performance is a potential challenge.

## 2.2 UDDTs introduced in rural Vietnam: continuous defecation use

At month 39 following the installation of the UDDTs, 65.8% of the units remained in continuous use (Table 4). Of the toilets that had not been seriously damaged, more than 80% were still in use. Given the 3-year non-intervention period, these proportions can be considered to be high and an indicator of the suitability of UDDTs for continuous defecation use. However, long-term physical damage, primarily from the strong highland winds, remained a major challenge to continuous use.

The high levels of suitability of the project UDDTs for continuous defecation use was potentially associated with good fecal chamber condition. The by-condition breakdown in Table 5 reveals that only a small proportion of UDDTs had offensive smells, maggots, and/or more than 10 flies in the fecal chambers. While fecal smell had been a particularly strong concern prior to installation, the proportion of UDDTs reported to have a bad smell was only 14%. These results indicate that the fecal chambers retained a satisfactory interior status even after the 3-year no-intervention period. The results in Figure 9 focus on the relation between smell and chamber condition, revealing that smell was significantly reduced in chambers that were in good condition. This suggests

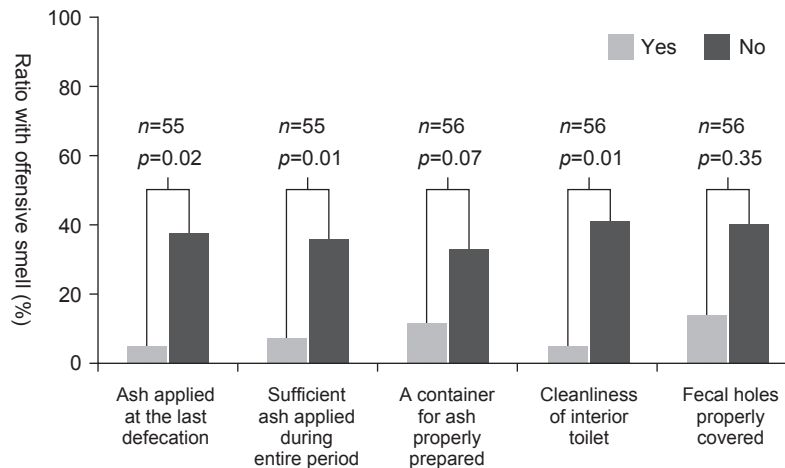

**Figure 9. Proportion of toilets with offensive fecal smell by conditions.**

Significant differences were tested using the Mann-Whitney U-test.

(Adopted from Harada et al. 2009)

**Table 6. Improper use of feces and urine at month 39.**

Check item	% of UDDTs in use
Fecal matter never used for agriculture	58.8
Urine not used for agriculture	65.4

that, through proper fecal chamber management, an acceptable defecation enclosure without offensive smell can be successfully provided to users.

A potential reason for the long-term sustainability of proper UDDT operation was the continuous house-by-house instruction on toilet management provided by a local health worker whose family also owned the UDDT. According to our interview of this worker, she irregularly administered instruction up to month 39, although her activities during months 6–39 could not be confirmed by the authors. As reported in Harada et al. (2004b), a typical improper practice during the project involved the incorrect use of ash in the fecal chamber; however, this was corrected during the continuous instruction provided during months 0–5. This continuous effort to train people to properly use the fecal chambers possibly kept the sanitization process running smoothly, resulting in reduced smell and more comfortable defecation rooms.

The agricultural use of feces and urine results recorded at month 39 are summarized in Table 6. Of the households who adopted the use of UDDTs, 58.8% had never used collected feces for agriculture over the course of the project, while 65.4% were not currently using the urine. Thus, the UDDTs were generally accepted for continuous defecation use, whereas the majority of UDDT users did not utilize the feces and/or urine, and the adoption of such measures remained a major unresolved challenge of the project.

### 2.3 UDDTs introduced in rural Malawi: continuous feces use for agriculture

Table 7 summarizes the operational conditions of the UDDTs in the Malawi Ecosan project, which had been installed 5–9 years prior to the survey. Eighty percent of the 277 household UDDTs were still in use, with the primary reason for ceasing use identified as physical damage to toilets as a result of heavy rains and/or strong winds. Similarly to the case in Vietnam, physical damage to the UDDT structure was a major challenge to continuous use.

**Table 7. Proportion of toilet, feces, and urine use (n = 277).**  
(Data from Harada et al. (2018))

	n (%)
Toilet use	221 (80%)
Feces used	216 (78%)
Urine used	79 (29%)

**Table 8. Eight components of integrated community development plan in NICCO Malawi project. (NICCO 2015)**

Eight components	Activities
Ecological sanitation	UDDT introduction
Reforestation	Moringa and Jatropha planted; 5,520 fruit trees planted; useful trees introduced; improved oven stoves introduced
Agricultural technology transfer	Organic farming; permaculture; distribution of local seeds; use of feces and urine
Human resource development	Fostering of local leaders; development of project, agriculture, women's, and health committees; workshop for local people
Infectious disease control	Malaria control; HIV prevention; infectious diseases control
Water supply	Construction of wells; workshop for village level operation and maintenance
Maternal and child health	Education activities for maternal and child health; introduction of bicycle ambulance
Income creation	Product development using local agricultural product

Feces from 78% of the total installed UDDTs (98% of the UDDTs in use) were used for agriculture, while urine from only 29% of all UDDTs (36% of the UDDTs in use) was used. This proportion of UDDTs with fecal use in Malawi was significantly higher than that in the Vietnam study (41.2%) although the people in Malawi had never experienced human excreta use for agriculture. According to Harada et al. (2018), 98% of the UDDT users reported yield increases from using feces for agriculture, while only 44% reported increases from the use of urine; these figures reflect the respective proportions of feces and urine use. These indicate that regardless the cultural background of human excreta use for agriculture, human excreta can be utilized if people perceived its value to agriculture.

Although the use of feces is understood to be beneficial for agriculture, there are in fact much higher proportions of nutrients such as nitrogen, phosphorus, and potassium in urine (Matsui et al. 2001). Urine use, therefore, should be prioritized more than feces from an agricultural nutrient perspective and used more widely to effectively increase the yield of agricultural production. Nevertheless, the proper use of Ecosan urine remained as an unresolved challenge to the project. In fact, the agricultural value of urine was explained to the local population according to our interviews to NICCO personnel. One of possible reasons for the great difference between the use of urine and feces is their knowledge and/or previous experiences to use animal manure. The use of animal manure was widely recognized by local people in the area, which might positively affected the continuous use of feces, whereas the use of animal urine separately collected from feces was not recognized, which lead to a greater psychological barrier to use human urine than feces. It appears that its successful continued use would require some change of their perception concerning its value.

Next to the perception on the value of feces, another possible reason of the remarkably different ratios of feces use in Malawi and Vietnam was how these 2 Ecosan projects were structured. Whereas the Ecosan project in Vietnam was solely conducted, the Ecosan project in Malawi was a part of 8 integrated community development activity components, as summarized in Table 8. In this integrated structure, the Ecosan approach was not introduced as a standalone practice but was instead directly connected to an agriculture technology transfer effort to promote effective use of human waste for agriculture. Demonstration farms were used to instruct how urine and feces could be used for agriculture, enabling the participants to recognize the effect of using human waste on agriculture. This integrated educational environment likely contributed to the above-mentioned high perception of the agricultural value of feces and spurred a high ratio of continuous use. In addition, other agriculture, health, and human resource components were also indirectly associated with Ecosan. By integrating Ecosan in this manner, a demand for agricultural use of feces was successfully created.

## Conclusion

In this paper, we examined the challenges to and potentials for Ecosan based on 3 cases in Vietnam and Malawi from the viewpoint of 3 essential requirements: health risk reduction, continuous defecation use, and excreta use. The experience with traditional dry toilets in rural Vietnam suggested that dry sanitation including Ecosan practices is effective at reducing the fecal contamination of the surrounding water environment, thereby limiting the health risk from unavoidable accidental ingestion of water. However, the long-term sustainability of sanitization performance of the toilets and the health risk reduction from manure handling and agricultural product application remained as challenges. The experience with the introduction of modern UDDTs in rural Vietnam indicated that the UDDTs could be continuously used for long-term defecation use even without intervention, with physical damage to the UDDT structure constituting the primary challenge to continuous use. In this case, proper management of the fecal chamber proved successful at controlling offensive fecal smells. The experience with the introduction of modern UDDTs to rural Malawi demonstrated that, even without cultural background of human excreta use, a high demand for feces use could be successfully created through association with a perception of the value of feces in agriculture and by integrating the Ecosan project into an agricultural technology transfer program. Urine use, by contrast, was not accepted widely and changing the perception of the usefulness of urine in agriculture was suggested as a key challenge that should be overcome. Thus, although some challenges still remain, 3 cases of Ecosan showed bright potentials of the Ecosan approach in terms of the 3 aspects: health risk reduction, continuous defecation use, and excreta use. Further academic studies and/or practical experience will be required to overcome the identified challenges and forward the successful scaling up of Ecosan.

## Acknowledgements

This study was supported by “The Sanitation Value Chain: Designing Sanitation Systems as Eco-Community Value System” Project, Research Institute for Humanity and Nature (RIHN, Project No.14200107), JSPS KAKENHI Grant No. 18H02312, and KU-GSGES Young Faculty Funding.

## References

Bui, T. C., Duong T. P. and Bui C. C. 2001. Biological Study on Retention Time of Microorganisms in Faecal Material in Urine-Diverting Eco-San Latrines in Vietnam. *Proceedings of the First International Conference*

- on *Ecological Sanitation*. Online. [http://www.ecosanres.org/Nanning\\_Conf\\_Proceedings.htm](http://www.ecosanres.org/Nanning_Conf_Proceedings.htm) (Accessed July 4, 2019)
- Drangert, J. 2004. *Norms and Attitudes Towards Ecosan and Other Sanitation Systems*. SEI (Stockholm Environment Institute), Stockholm.
- Esrey, S. A., Gough, J., Rapaport, D., Sawyer, R., Simpson-Hébert, M., Vargas, J., Winblad, U. 1998 *Ecological Sanitation*. Edited by Winblad U. Sida (Swedish International Development Cooperation Agency), Stockholm.
- Harada, H., Matsui, S., Matsuda, T., Shimizu, Y., Utsumi, H., Ono, S., Duong, T. P. and Winblad, U. 2004a. Implementation of the Project to Introduce Ecological Sanitation Toilets to a Minority Hamlet of Vietnam. *Proceedings of the Symposium on Global Environment*; 12: 135–140. <https://doi.org/10.2208/proge.12.135>
- Harada, H., Utsumi, H., Matsuda, T., Winblad, U., Ono, S. and Matsui, S. 2004b. Improvement of Sanitary Conditions in Danphuong Village, Vietnam. *Environmental & Sanitary Engineering Research* 18(2): 22–30.
- Harada, H., Matsui, S., Duong, T. P., Shimizu, Y., Matsuda, T. and Utsumi, H. 2006. *Keys for Successful Introduction of Ecosan Toilets: Experiences from an Ecosan Project in Vietnam*. Paper Presented at the IWA 7th Specialised Conference on Small Water and Wastewater Systems, March 7–10, 2006. Mexico City, Mexico.
- Harada, H., Fujii, S. and Matsui, S. 2009. Appraisal of an Ecological Sanitation Project Focusing on Post-Intervention Practices. *Proceedings of the 3rd Specialised Conference of Decentralized Water and Wastewater International Network*; 1–8.
- Harada, H., Fujii, S., Kuroda, M., Sakaguchi, R., Nugyen, P. H. L. and Trung, H. H. 2016. Probabilistic Microbial Exposure Analysis in an Excreta-Using Community of Rural Hanoi. *Proceedings of International Conference Environmental Engineering and Management for Sustainable Development*; 111–116.
- Harada, H., Mchwampaka, D. A. and Fujii, S. 2018. Long-Term Acceptability of UDDTs: A Case Study in Rural Malawi. *Sandec News* 19: 7.
- Jackson, B. 2005. *A Review of EcoSan Experience in Eastern and Southern Africa*. WSP-Africa, Nairobi.
- Jonsson, H., Stinzing, A. R., Vinneras, B. and Salomon, E. 2004. *Guidelines on the Use of Urine and Faeces in Crop Production*. SEI (Stockholm Environment Institute), Stockholm.
- Julian, T. R., Hasitha, S. K., Vithanage, M. L. C., Kuroda, M., Pitol, A. K., Hong, P., Nguyen, L., Canales, R. A., Fujii, S. and Harada, H. 2018. High Time-Resolution Simulation of *E. coli* on Hands Reveals Large Variation in Microbial Exposures amongst Vietnamese Farmers Using Human Excreta for Agriculture. *Science of The Total Environment* 635: 120–131. <https://doi.org/10.1016/j.scitotenv.2018.04.100>
- Kaku, T., Ota, K., Takesue, M., Harada, H., Ono, S., Uetani, M. and Kodama, M. 2004. Medical Activities in a Minority Hamlet, DanPhuong Village, LamDong Province, Vietnam- Summary of Three-Year Activities. *Proceeding of the 9th Research Seminar of International Medical Services in Shiga*.
- Matsui, S., Henze, M., Ho, G. and Otterpohl, R. 2001. Emerging Paradigms in Water Supply and Sanitation. In Maksimovic, C. and Tejada-Guibert, J. A. (eds) *Frontiers in Urban Water Management (Deadlock or Hope)*. pp. 229–263. IWA Publishing, London.
- Nha Trang Pasteur Institute VinaSanres Project 2002. *Vinasanres Double Vault Toilets - Construction and Use*. Nha Trang Pasteur Institute, Nha Trang.
- NICCO (Nippon International Cooperation for Community Development) 2015. *Malawi de no 7 nenkan: Kiga no Okinai Mura-zukuri マラウイでの7年間: 飢餓の起きない村づくり (7-Year Community Development Activities in Malawi)*. Posted at 2015. Online. <https://kyoto-nicco.org/africa/malawi.html> (Accessed July 4, 2019).
- Pham, H. G., Harada, H., Fujii, S., Nguyen, P. H. L. and Huynh, T. H. 2017. Transition of Human and Livestock Waste Management in Rural Hanoi: A Material Flow Analysis of Nitrogen and Phosphorus during 1980–2010. *Journal of Material Cycles and Waste Management* 19: 827–839. <https://doi.org/10.1007/s10163-016-0484-1>

- Pham, H. G., Harada, H., Fujii, S., Nguyen, P. H. L., Huynh, T. H., Pham, N. A. and Tanaka, S. 2015. Transition of Fertilizer Application and Agricultural Pollution Loads: A Case Study in the Nhue-Day River Basin. *Water Science & Technology* 72(7): 1072–1081. <https://doi.org/10.2166/wst.2015.312>
- Uddin, S. M. N., Muhandiki, V. S., Sakai, A., Al Mamun, A. and Hridi, S. M. 2014. Socio-Cultural Acceptance of Appropriate Technology: Identifying and Prioritizing Barriers for Widespread Use of the Urine Diversion Toilets in Rural Muslim Communities of Bangladesh. *Technology in Society* 38: 32–39. <https://doi.org/10.1016/j.techsoc.2014.02.002>
- Werner, C., Panesar, A., Rüd, S. B. and Olt, C. U. 2009. Ecological Sanitation: Principles, Technologies and Project Examples for Sustainable Wastewater and Excreta Management. *Desalination* 248(1–3): 392–401. <https://doi.org/10.1016/j.desal.2008.05.080>
- WHO (World Health Organization) and UNICEF (United Nations International Children’s Education Fund) 2017. *Progress on Drinking Water, Sanitation and Hygiene: 2017 update and SDG baselines*. WHO and UNICEF, Geneva.
- WHO (World Health Organization) and UNICEF (United Nations International Children’s Education Fund) 2019. “Households.” *JMP (Joint Monitoring Programme) on the web: JMP Global Database*. Online. <https://washdata.org/data/household#!/> (Accessed July 4, 2019).
- Winblad, U. and Simpson-Hébert, M. 2004 *Ecological Sanitation*, revised and enlarged ed. SEI (Stockholm Environment Institute), Stockholm.



# Development of Separation Process of Soluble Nutrients from Synthetic Dairy Slurry by Modified Solvay Process

Minami FUJIOKA<sup>1</sup> and Ryusei ITO<sup>1</sup>

<sup>1</sup> Faculty of Engineering, Hokkaido University, Japan

## Abstract

There is a huge problem with the reuse of dairy slurry (i.e., liquid fraction of dairy manure) which has a high potential as a fertilizer in Japan. The dairy farmer applies too much dairy slurry to their farm for pasture and meadow, because they have a huge amount of slurry production, resulting in over-fertilizing and also causing a bad odor problem. To overcome these problems, the nutrients should be used for other crops managed by other farmers. This is, however, costly due to transportation and a special machine needed for its application. Furthermore, nutrient salt concentrations of slurry as such is improper. Therefore, the solid fertilizers production process (SFPP) from dairy slurry is proposed to produce ammonium sulfate and potassium chloride as fertilizers, and sodium hydrogen carbonate as a by-product. The objectives of this research are 1) to investigate the effect of temperature on sodium hydrogen carbonate precipitation and 2) to confirm the principle of separated precipitation of sodium and potassium. As a result, precipitation of sodium hydrogen carbonate was observed in the temperature range from 25°C to 50°C. The sodium concentration in precipitation was high at 25°C among the experiments. Then, the sodium removal and potassium recovery processes produced sodium hydrogen carbonate and potassium chloride precipitations separately, without ammonia in the precipitations. The element analysis and XRD analysis supported the existence of the crystals. Finally, the possibility of separate production of potassium fertilizer and sodium salt was confirmed.

*Keywords: solid fertilizers, crystallization, distillation, potassium chloride, sodium hydrogen carbonate*

## Introduction

A significant amount of livestock waste, which is approximately 31,200 kilometric tonnes of feces and 9,700 kilometric tonnes of urine, are discharged from cattle barns every year in Japan (Kobayashi 2001). The mixture of feces and urine from cows reared by 45% of dairy farmers in Japan was separated into solid and liquid fractions by gravity separation, while the other farmers kept it in a mixed form (MAFF 2009). Generally, the solid fraction consisting of large particles like litter and cake of feces is processed for solid compost, to be provided to grains cultivating farmers. The liquid fraction called “dairy slurry” which contains small particles, soluble materials and water are stored in a storage tank then used as liquid fertilizers. Table 1 shows the composition of liquid waste and fresh cow urine that were measured in previous research (Kaneko et al. 2014) and a preliminary experiment. The dairy slurry and urine were taken from dairy farms in the northern part of Sapporo city and in Nakashibetsu town, Hokkaido, Japan. The liquid wastes richly contain ammonia—which accounts for 62% of total nitrogen—potassium, sodium but the low concentration of phosphorus.

According to statistical data by the Food and Agriculture Organization of the United Nations (FAO) (FAO 2015), 599 kilometric tonnes of ammonium sulfate and 434 kilometric tonnes of potassium chloride, which are one of the most common chemical fertilizers in Japan, were annually consumed as fertilizers in Japan on average from

**Table 1. Characterization of liquid waste and cow urine.**

Parameter	Units	Dairy slurry at Sapporo	Dairy slurry at Nakashibetsu	Cow urine at Sapporo	Cow urine*
pH	-	7.5	7.1	8.2	-
NH <sub>4</sub> <sup>+</sup> -N	mmol/L	78.38	59.37	5.26	56.7
Urea	mmol/L	-	-	-	430.0
TN	mmol/L	125.80	-	476.49	-
K	mmol/L	115.09	309.48	135.04	202.0
Na	mmol/L	45.85	85.26	131.36	59.2
Mg	mmol/L	21.81	17.61	16.31	9.6
Ca	mmol/L	16.89	61.63	0.10	5.6
Cl	mmol/L	48.78	-	20.73	286.6
PO <sub>4</sub> <sup>3-</sup>	mmol/L	1.13	1.03	0.02	2.5
TP	mmol/L	2.52	14.95	0.59	-
SO <sub>4</sub> <sup>2-</sup>	mmol/L	2.00	-	17.33	25.6
TOC	mg/L	10,279	1,655	15,550	-

\* Literature value (Kaneko et al. 2014)

2010 to 2015. By comparison of annual fertilizer consumption with the amount of nutrients in liquid waste, the annual discharge of ammonia in liquid waste accounts 21 kilometric tonnes, which shares 4% of annual ammonium sulfate consumption, and that of potassium in liquid waste was 86 kilometric tonnes which equivalent to 20% of annual potassium chloride consumption (Ikumo 2002; MAFF 2015). This fact indicates that the effective utilization of liquid waste as nutrients resource leads us to reduce the annual consumption of chemical fertilizers. Japan Ministry of Agriculture, Forestry and Fisheries is promoting a group farming in the cooperation system between the cultivation and livestock sectors. This system aims to make the material cycle by reusing dairy wastes for animal feed production and works effectively (Nakamura 2012; Nishida et al. 2013). However, the direct reuse of liquid wastes into farmlands requires special machines for the application like a slurry tanker, slurry spreader or slurry injector which only dairy farmers have, while cultivation farmers have fertilizer sower machine to apply solid granules like conventional chemical fertilizer. And also the reuse causes the odor problem by ammonia, salt accumulation into the soil, and excess accumulation of potassium for grass resulting in grass tetany (Wylie et al. 1985; Schonewille et al. 1999; TRES Co. Ltd. 2016) or milk fever (Nakamura 2012). On the other hand, our measurement of the concentration nitrogen, potassium, and phosphorus showed the nutrient balance of the liquid wastes was not suitable for the growth of plants requiring adjustment of their compositions. Moreover, transportation cost is very huge, e.g. farmers need 3–4 metric tonnes of dairy slurry for 1,000 m<sup>2</sup> farmland while paying 4,800 JPY/metric tonne-compost for 100 km transportation (Yakushido 2000), which is almost same as the equivalent value as chemical fertilizers (Nakamura 2012). These factors are a cause that dairy farmers apply liquid waste for cultivating pasture and meadow in their farmland resulting in over-fertilizing (Haga 2006). In order to overcome these problems, solid fertilizers with a single nutrient are required to provide high volume concentration, adjustable composition, and less odor. There are several technologies to produce solid nitrogen and phosphate fertilizers from human urine by producing ureaform (Ito et al. 2013; Kabore et al. 2016a, b), insoluble precipitation (Udert et al. 2015; Ito and Funamizu 2016), adsorption (Ganesapillai et al. 2015), biological accumulation (Cech and Hartman 1993) and concentration (Ek et al. 2006; Pahore 2010, 2011a, b; Antonini et al. 2012; Nikiema et al. 2017). These technologies require the collection of fresh urine to avoid urea hydrolysis and a huge amount of additional materials for concentration. Therefore, we propose the solid fertilizers production process (SFPP) from dairy liquid waste. The SFPP from dairy slurry employs continuous processes of ammonia stripping coupled with

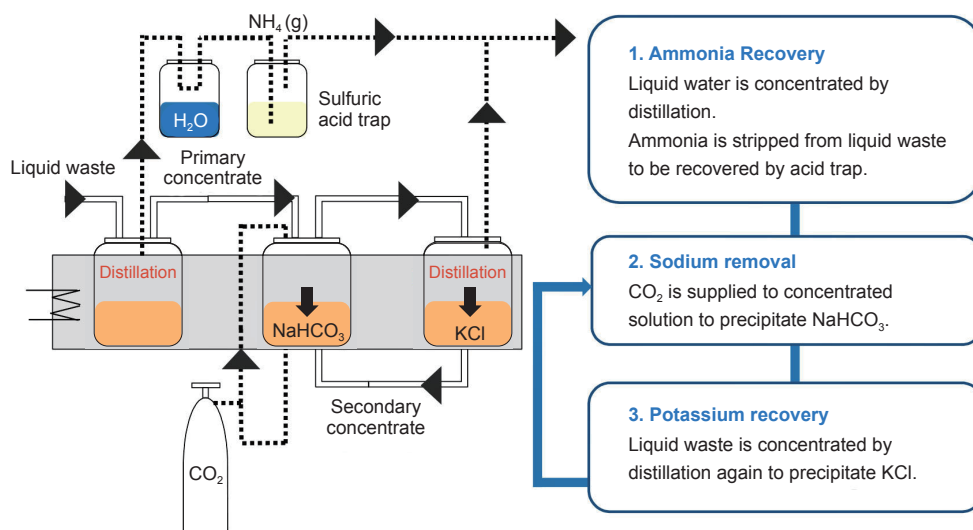

Figure 1. Overall view of solid fertilizer production process from liquid waste.

acid absorption and concentration by distillation and precipitation of sodium and potassium salts, whose overall view is shown in Figure 1. In the first step, the slurry is concentrated by a distillation process, while ammonia in the liquid is recovered by sulfuric acid to precipitate ammonium sulfate. In this process, the concentrations of sodium, potassium and other accumulative elements might be concentrated in 10 folds. Carbon dioxide is supplied to the concentrated solution to precipitate sodium carbonate at the second step. After solid-liquid separation, the liquid is concentrated again to form the precipitation of potassium chloride at the third step. The precipitation is recovered then the liquid is returned into the second step for keeping the high concentration of the solutes. Sodium is removed as sodium hydrogen carbonate prior to the potassium recovery process. This process was designed based on the solubility data of sodium chloride, potassium chloride, sodium hydrogen carbonate and potassium hydrogen carbonate (National Astronomical Observatory 2017). The solubility of sodium chloride is higher than that of potassium chloride at 70°C and less, while that of sodium hydrogen carbonate is lower than that of potassium hydrogen carbonate. Because of design from solubility data for single component, the rough operation condition and principle confirmation are required to demonstrate the possibility of SFPP. The ammonium recovery was confirmed in our preliminary experiments. The objective of this research was to confirm the sodium removal and potassium recovery processes on production processes of solid fertilizer from the dairy slurry from dairy farms.

## 1. Materials and Methods

### 1.1. Determination of operation temperature

The SFPP contains evaporation and crystallization processes which respectively prefer higher and lower temperatures, resulting in heating at evaporation and cooling at precipitation. To reduce energy consumption for the SFPP, we decided to set the same temperature for both processes. The SFPP expects the precipitations of sodium hydrogen carbonate and potassium chloride, so the operating temperature at which both crystals precipitates was explored. Five hundred milliliters of the synthetic dairy slurry with simple components (SDL-s), whose composition summarized in Table 2, were taken in an airtight bottle under the constant temperature. CO<sub>2</sub> gas was supplied to the solution through a bubbling needle with stirring by a magnetic stirrer. The bubbling

**Table 2. Compositions of synthetic liquid waste.**

60°C		50°C		40°C		30°C		25°C	
Salt	mol/L	Salt	mol/L	Salt	mol/L	Salt	mol/L	Salt	mol/L
NaCl	4.0	NaCl	4.0	NaCl	3.5	NaCl	2.7	NaCl	2.7
KCl	2.7	KCl	2.7	KCl	2.5	KCl	2.5	KCl	2.5
(NH <sub>4</sub> ) <sub>2</sub> CO <sub>3</sub>	0.5	(NH <sub>4</sub> ) <sub>2</sub> CO <sub>3</sub>	0.5	(NH <sub>4</sub> ) <sub>2</sub> CO <sub>3</sub>	0.5	(NH <sub>4</sub> ) <sub>2</sub> CO <sub>3</sub>	0.5	(NH <sub>4</sub> ) <sub>2</sub> CO <sub>3</sub>	0.5

continued for several hours until the precipitation is observed. Before and after CO<sub>2</sub> injection, 5 ml of the solution was taken and filtrated by a membrane filter with 0.45 µm pore size (ADVANTEC, 25CS045AN). After the sampling, the sample was immediately diluted with water to 10 times to avoid the precipitation due to the cooling of the solution. pH and temperature were measured with a pH meter (TOADKK, WM-22EP). Sodium, potassium, ammonium, and chloride concentrations were measured with an ion-chromatography analyzer (DIONEX, ICS-90). Carbon dioxide concentration was measured with a total organic carbon analyzer (SHIMADZU, TOC-5000A). The formed precipitate was collected by vacuum filtration with a 0.45 µm membrane filter (ADVANTEC, C045A09C) and dissolved in water after dry weight measurement. Sodium, potassium, ammonium, chloride, and carbon dioxide concentrations of the solution were measured with the same analytical methods as above for the determination of the composition of the precipitate. These processes were repeated for different temperatures.

## 1.2. Sodium removal and potassium recovery test

For verification of the sodium removal process, an airtight bottle with 500 ml of SDL-s was kept at 25°C. The concentration was the same as the previous experiment for 25°C. CO<sub>2</sub> gas which was injected for 3 hours by precipitations appeared. The solution was taken 5 ml before and after CO<sub>2</sub> injection and filtrated with the membrane filter, then diluted to 10 times. pH and temperature were measured with the pH meter. The precipitate was collected with vacuum filtration and dissolved in water after dry weight measurement. Sodium, potassium, and ammonium concentrations were measured with the ion chromatography analyzer, carbon dioxide concentration was measured with the total organic carbon analyzer. Furthermore, the crystal structure of the precipitates was analyzed with X-Ray Diffraction analysis (XRD).

According to the potassium recovery process, the filtrate from the experiment for sodium removal was concentrated 2 times ( $C_{f2} = 2$ ) by distillation with a rotary evaporator (EYELA, N-1000) under vacuum condition for potassium recovery. The distillation process was conducted with a digital water bath (EYELA, SB-1000) at 60°C. Five milliliters of the solution were samples and filtrated. To avoid the precipitation the solution was diluted to 10 times immediately. After the distillation process, the solution was cooled to 25°C for several hours, then precipitation occurred. The elements in the solution and dissolved precipitates were measured by the ion chromatography, while the crystal structure of the precipitates was analyzed by the XRD analysis.

## 2. Results and Discussion

### 2.1. Temperature effect on precipitation

Visible precipitation was observed at 25, 30, 40 and 50°C, but precipitation did not occur at 60°C. Table 3 shows the concentrations of ions before and after CO<sub>2</sub> injection at 25, 30, 40 and 50°C. As regards the experiments at 30°C, measured “Before” concentrations were significantly different from set concentrations as shown in

**Table 3. Concentrations of ions before and after CO<sub>2</sub> injection at each temperature.**

Element	unit	50°C		40°C		30°C		25°C	
		Before	After	Before	After	Before	After	Before	After
Na	mol/L	4.1	3.0	3.4	2.3	2.1	2.0	2.7	2.0
K	mol/L	2.6	1.6	2.4	2.4	2.4	2.6	2.5	2.4
Cl	mol/L	6.2	5.4	7.0	4.3	4.0	4.3	5.2	4.9
CO <sub>3</sub>	mol/L	0.0	0.3	0.0	0.5	0.0	0.6	0.0	0.4
NH <sub>4</sub>	mol/L	1.0	1.0	0.9	0.8	0.7	0.8	1.0	1.0
time	hours	7.0		4.5		4.0		3.0	

**Table 4. Simulated concentrations of ions after CO<sub>2</sub> injection at each temperature.**

Element	unit	50°C	40°C	30°C	25°C
Na	mol/L	2.2	1.7	1.1	1.1
K	mol/L	2.7	2.7	2.5	2.5
Cl	mol/L	6.7	6.2	5.2	5.2
CO <sub>3</sub>	mol/L	0.16	0.24	0.44	0.48
NH <sub>4</sub>	mol/L	1.0	1.0	1.0	1.0

Table 2, indicated the error of the measurements. Nevertheless, sodium concentrations decreased while potassium concentrations remained at the same level at 25 and 40°C. If sodium and potassium precipitate independently, the following reactions may occur to form precipitations, while the concentrations should be their solubility.

Sodium chloride precipitation:

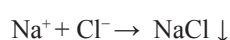

Potassium chloride precipitation:

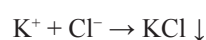

Sodium hydrogen carbonate precipitation:

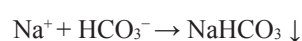

Here, sodium hydrogen carbonate precipitation will decrease only sodium concentration, in contrast, sodium chloride precipitation decreases the same amount of sodium and chloride. Chloride concentrations decreased as well at 25, 40 and 50°C, suggesting the precipitation of not only sodium hydrogen carbonate but also sodium chloride. To compare with literature data, the concentrations of sodium, potassium, chloride, and carbonate at equilibrium were simulated by PHREEQC software as summarized in Table 4 (Charlton and Parkhurst 2011; Parkhurst and Appelo 2013). This simulation showed that sodium hydrogen carbonate precipitated but sodium chloride and potassium chloride did not appear in the solution, because only sodium concentration decreased. In the case of the experiment at 50°C, all sodium, potassium and chloride concentrations decreased, and implied the precipitation of potassium chloride, sodium chloride, and sodium hydrogen carbonate. So, 50°C was used for further experiments. For further analysis of precipitations, the molar ratio of elements in precipitate collected in the experiment at 25°C was shown in Table 5, while Figure 2 shows the mass ratio of elements in precipitate collected in the experiment at 25°C. The collected precipitate was rich in sodium, while the ratio of CO<sub>2</sub> was lower than that of sodium. Approximately 10 mol% of sodium and 35 mol% of chloride were accounted for in the precipitate. Analysis of the collected precipitate suggested that CO<sub>2</sub> injection could form sodium hydrogen carbonate, although potassium chloride and sodium chloride could precipitate together. Further investigations into the relationship between the formation of sodium hydrogen carbonate and target temperature, also the relationship between the formation of sodium hydrogen carbonate and CO<sub>2</sub> injection time are needed.

**Table 5. Mole ratio of elements in precipitate (25°C).**

Element	Mole ratio
Na	1.00
K	0.17
Cl	0.35
NH <sub>4</sub>	n.d.
CO <sub>2</sub>	0.39

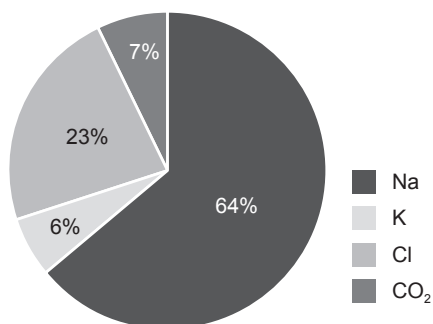
**Figure 2. Mass ratio of elements in precipitate (25°C).**

## 2.2. Sodium removal and potassium recovery test

Figure 3 shows the concentrations of sodium, potassium, chloride, ammonium and carbon dioxide in Na removal and K recovery processes. “Expected” stands for the ion concentrations in solution which were determined by multiplying “After Na removal” by a concentration factor of 2.2 for this experiment. The sodium concentration decreased from 2.7 mol/L to 2.0 mol/L through sodium removal process, while the potassium and ammonia concentrations remained the same. The chloride concentration slightly decreased from 5.2 mol/L to 4.9 mol/L. The differences in potassium and chloride concentrations between “Expected” and “After K recovery” indicated the precipitation of potassium chloride, while the potassium concentration was lower than the solubility of potassium chloride in water at 50°C. As well as potassium, sodium concentration decreased through the potassium recovery process, while the sodium concentration was lower than the solubility of sodium chloride in water at 50°C. Table 6 exhibits the molar ratio of elements in a precipitate that were collected from sodium removal and potassium recovery processes. As for sodium removal, the sum of the molar amounts of CO<sub>2</sub> and chloride in the precipitate were approximately equivalent to the molar amount of sodium in the precipitate which indicates the precipitation of both sodium chloride and sodium hydrogen carbonate. Moreover, ammonia was not detected in the precipitate. The ratio of potassium to chloride in the precipitate from the potassium recovery was approximately 0.9. Figures 4 and 5 respectively show the mass ratio of the elements in precipitate from the sodium removal and potassium recovery processes. The main components of the precipitate from sodium recovery were sodium and carbonate to indicate the existence of NaHCO<sub>3</sub> precipitation, while that from potassium recovery consists of KCl. This result shows the possibility of separation of sodium and potassium by the SFPP. Figures 6 and 7 respectively show the XRD analysis result of precipitate from sodium removal and potassium recovery. They suggested that precipitate collected from sodium removal process was a mixture of sodium hydrogen carbonate, potassium chloride, and sodium chloride, and the precipitate collected from potassium recovery was potassium chloride.

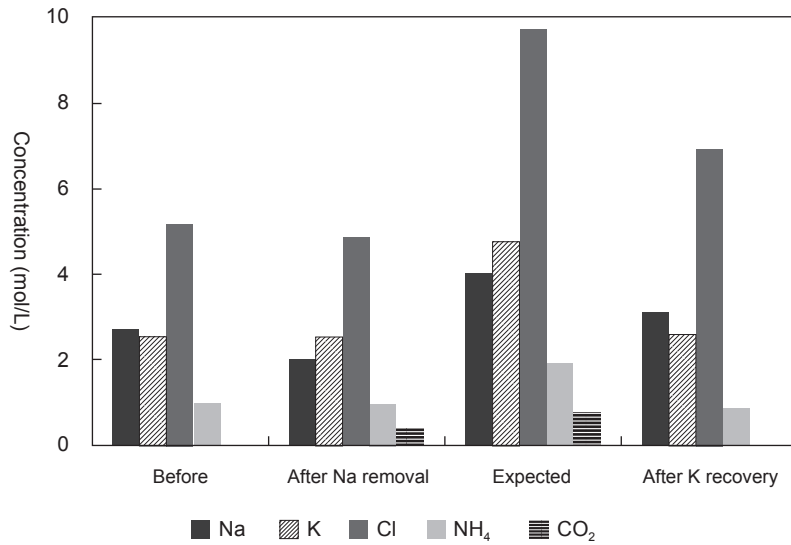
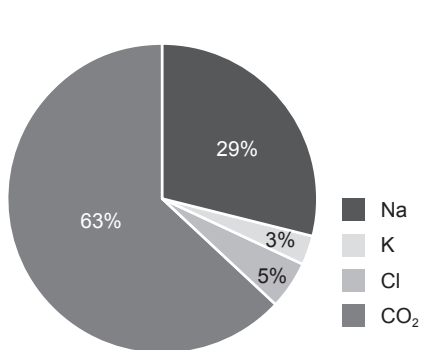

**Figure 3. Concentrations of sodium, potassium, chloride, ammonium and carbon dioxide in Na removal and K recovery processes.**

Before: before CO<sub>2</sub> injection, After Na removal: after CO<sub>2</sub> injection, Expected: estimated concentration after the concentration process of the liquid from “After Na removal”, and After K recovery: after the concentration process with the liquid from “After Na removal”.

**Table 6. Mole ratio of elements in collected precipitates.**

Element	Na removal	K recovery
Na	1.00	1.00
K	0.06	14.83
Cl	0.40	16.85
NH <sub>4</sub>	n.d.	1.21
CO <sub>2</sub>	0.45	n.d.



**Figure 4. Mass ratio of elements in precipitate (Sodium removal).**

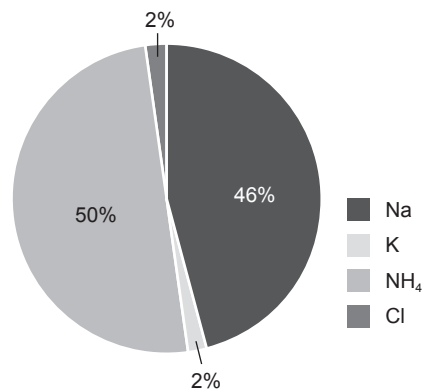

**Figure 5. Mass ratio of elements in precipitate (Potassium recovery).**

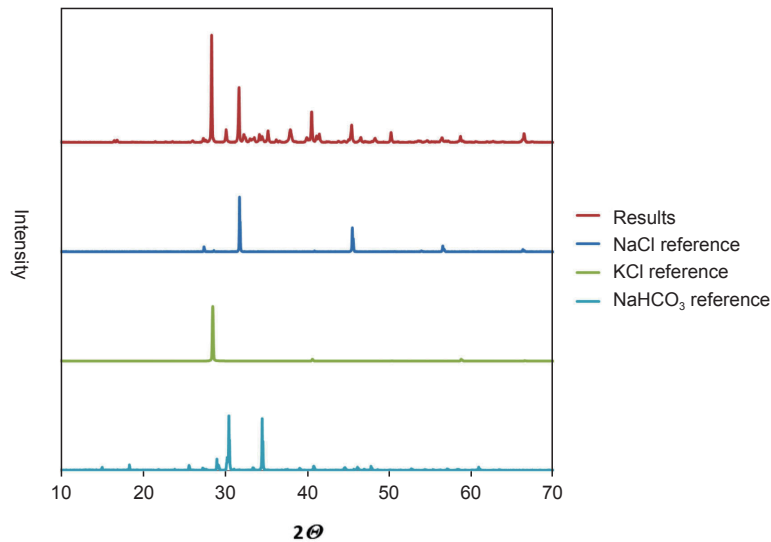

Figure 6. XRD analysis result (Sodium removal).

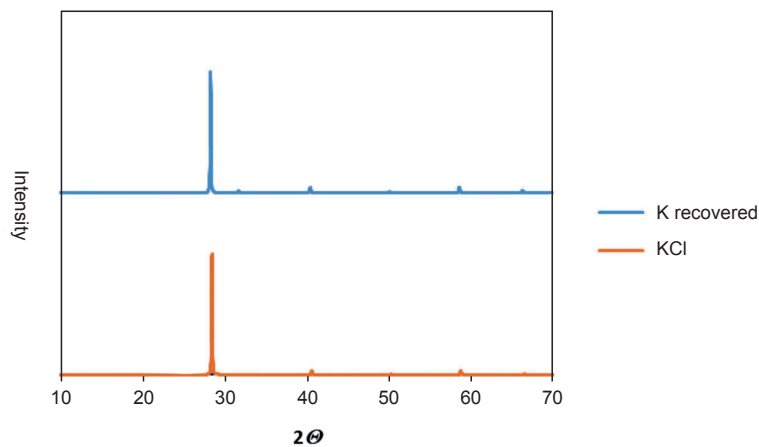

Figure 7. XRD analysis result (Potassium recovery).

## Conclusion

A solid fertilizers production process from dairy liquid waste was proposed, which produces ammonium sulfate and potassium chloride as fertilizers, and sodium hydrogen carbonate as a by-product. In this paper, to assess the possibility of the process with synthetic dairy liquid waste, the effect of temperature on sodium hydrogen carbonate precipitation was investigated, while the possibility of separated precipitation of sodium and potassium. As a result, sodium hydrogen carbonate was precipitated in the temperature range from 25°C to 50°C, and the precipitation at 25°C had the highest sodium content among the precipitates from the experiments. The temperature swing method for sodium removal and potassium recovery processes was produced by sodium hydrogen carbonate and potassium chloride precipitations separately, while ammonia did not contain in the precipitations. The element analysis and XRD analysis supported the existence of the crystals. Then, the possibility of separate production of potassium fertilizer and sodium salt was confirmed. For further study, the demonstration test of the SPFF and cultivation test with the produced fertilizer should be conducted.



## References

- Antonini, S., Nguyen, P. T., Arnord, U., Eichert, T. and Clemens, J. 2012. Solar thermal evaporation of human urine for nitrogen and phosphorus recovery in Vietnam. *Science of the Total Environment* 414: 592–599. <https://doi.org/10.1016/j.scitotenv.2011.11.055>
- Cech, J. S. and Hartman, P. 1993. Competition between polyphosphate and polysaccharide accumulating bacteria in enhanced biological phosphate removal systems. *Water Research* 27(7): 1219–1225. [https://doi.org/10.1016/0043-1354\(93\)90014-9](https://doi.org/10.1016/0043-1354(93)90014-9)
- Charlton, S. R. and Parkhurst, D. L. 2011. Modules based on the geochemical model PHREEQC for use in scripting and programming languages. *Computers and Geosciences* 37(10): 1653–1663. <https://doi.org/10.1016/j.cageo.2011.02.005>
- Ek, M., Bergström, R., Bjurhem, J. E., Björlenius, B. and Hellström, D. 2006. Concentration of nutrients from urine and reject water from anaerobically digested sludge. *Water Science and Technology* 54(11–12): 437–444. <https://doi.org/10.2166/wst.2006.924>
- FAO (Food and Agriculture Organization of the United Nations) 2015. *FAOSTAT*. Online. <http://faostat3.fao.org/home/E> (Accessed September 1, 2015)
- Ganesapillai, M., Simha, P. and Zabaniotou, A. 2015. Closed-loop fertility cycle: Realizing sustainability in sanitation and agricultural production through the design and implementation of nutrient recovery systems for human urine. *Sustainable Production and Consumption* 4: 36–46. <https://doi.org/10.1016/j.spc.2015.08.004>
- Haga, K. 羽賀清典 2006. Kachiku Haisetsu Butsu no Baiomasu Riyo 家畜排泄物のバイオマス利用 (Application of biomass from livestock manure). *Fudo Sisutemu Kenkyu* フードシステム研究 13(2): 22–31. [https://doi.org/10.5874/jfsr.13.2\\_22](https://doi.org/10.5874/jfsr.13.2_22)
- Ikumo, H. 生雲晴久 2002. Gijutsu Joho “Chikusan Tokei” ni Motoduku Kachiku Haisetsu Butsu Chu no Chisso, Rin, Kariumu Haisetsu Ryo no Suitei 技術情報「畜産統計」にもとづく家畜排泄物中の窒素, リン, カリウム排泄量の推定 (Estimation of NPK amount in livestock excreta by the data from Statistical Survey on Livestock). *Chikusan Gijutsu* 畜産技術 560: 46–49.
- Ito, R. and Funamizu, N. 2016. Phosphate Recovery from Synthetic Urine with Shell of *Mizuhopecten yessoensis*. *Journal of Water and Environment Technology* 14(6): 437–446. <https://doi.org/10.2965/jwet.16-007>
- Ito, R., Takahashi, E. and Funamizu, N. 2013. Production of slow-released nitrogen fertilizer from urine. *Environmental Technology* 34(20): 2809–2815. <https://doi.org/10.1080/09593330.2013.790069>
- Kabore, S., Ito, R. and Funamizu, N. 2016a. Effect of Formaldehyde/Urea Ratio on Production Rate of Methylene Urea from Human Urine. *Journal of Water and Environment Technology* 14(2): 47–56. <https://doi.org/10.2965/jwet.15-016>
- 2016b. Reaction kinetics for the production of methylene urea from synthetic human urine. *Journal of Environmental Chemical Engineering* 4(2): 2510–2517. <https://doi.org/10.1016/j.jece.2016.04.028>
- Kaneko, S., Ito, R. and Funamizu, N. 2014. Effect of Burned Shell Dosage on Crystat Species in Synthetic Cow Urine. *Proceedings of 9th IWA International Symposium on Waste Management Problems in Agro-Industries*; I: 465–469.
- Kobayashi, S. 小林茂樹 2001. *Kankyo ni Chowa Shita Kachiku no Seisan Gijutsu Kanri* 環境に調和した家畜の生産・管理技術 (Production and management of livestock in harmony with the environment). Tsukuba Shobo, Tokyo.
- MAFF (Ministry of Agriculture, Forestry and Fisheries) 農林水産省 2009. *Chikusan Tokei Chosa* 畜産統計調査 (The Statistical Survey on Livestock). Online. <https://www.maff.go.jp/j/tokei/kouhyou/tikusan/> (Accessed February 20, 2020)
- 2015. *Chikusan Tokei Chosa* 畜産統計調査 (The Statistical Survey on Livestock). Online. <https://www.maff.go.jp/j/tokei/kouhyou/tikusan/> (Accessed February 20, 2020)
- Nakamura, M. 中村稔 2012. Rakuno Baio Gasu Sisutemu ni okeru Metan Hakko Yurai Shouka Eki no Katsuyo no

- Koka 酪農バイオガスシステムにおけるメタン発酵由来消化液の活用の効果 (The effects of practical usage of the digested slurry to biogas system). *Rakuno Gakuen Daigaku Kiyo* 酪農学園大学紀要 36(2): 77–122.
- National Astronomical Observatory 国立天文台 2017. Rika Nenpyo 理科年表 (Chronological Scientific Tables). Maruzen, Tokyo. Online. <https://www.rikanenpyo.jp/> (Accessed July 10, 2019)
- Nikiema, B. C. W.-Y., Ito, R., Guizani, M. and Funamizu, N. 2017. Estimation of Water Flux and Solute Movement during the Concentration Process of Hydrolysed Urine by Forward Osmosis. *Journal of Water and Environment Technology* 15(5): 163–173. <https://doi.org/10.2965/jwet.16-074>
- Nishida, T., Oishi, K., Choumei, Y., Kumagai H. and Hirooka, H. 西田俊也, 大石風人, 長命洋佑, 熊谷元, 広岡博之 2013. Senkei Keikaku Ho wo Mochiita Kouchiku Renkei Sisutemu no Kankyo Keizai Sei Hyoka Ho no Kakuritsu 線形計画法を用いた耕畜連携システムの環境・経済性評価法の確立—国家レベルでの水田利活用の検討 (Environmental and economic evaluation for integration systems between crop and animal production using linear programming: Utilization of paddy rice fields at national level). *Nihon Chikusan Gakkaiho* 日本畜産学会報 84(4): 475–486. <https://doi.org/10.2508/chikusan.84.475>
- Pahore, M. M., Ito, R. and Funamizu, N. 2010. Rational Design of an On-Site Volume Reduction System for Source-Separated Urine. *Environmental Technology* 31(4): 399–408. <https://doi.org/10.1080/09593330903505654>
- 2011a. Performance evaluation of an on-site volume reduction system with synthetic urine using a water transport model. *Environmental Technology* 32(9–10): 953–970. <https://doi.org/10.1080/09593330.2010.521954>
- Pahore, M. M., Ushijima, K., Ito, R. and Funamizu, N. 2011b. Fate of nitrogen during volume reduction of human urine using an on-site volume reduction system. *Environmental Technology* 33(2): 229–235. <https://doi.org/10.1080/09593330.2011.560192>
- Parkhurst, D. L. and Appelo, C. A. J. 2013. *Description of Input and Examples for PHREEQC Version 3 — A Computer Program for Speciation, Batch-Reaction, One-Dimensional Transport, and Inverse Geochemical Calculations: U.S. Geological Survey Techniques and Methods, book 6, chapter A43*. U.S. Geological Survey, Colorado: Denver. Online. <https://pubs.usgs.gov/tm/06/a43/> (Accessed February 20, 2020)
- Schonewille, J. T. Van't Klooster, A. T., Wouterse, H. and Beynen, A. C. 1999. Effects of intrinsic potassium in artificially dried grass and supplemental potassium bicarbonate on apparent magnesium absorption in dry cows. *Journal of Dairy Science* 82(8): 1824–1830. [https://doi.org/10.3168/jds.S0022-0302\(99\)75413-5](https://doi.org/10.3168/jds.S0022-0302(99)75413-5)
- TRES Co. Ltd. 株式会社TRES 2016. *Kachiku Haisetsu Butsu tou Baiomasu wo Katsuyoushita Hatsudentou Enerugi Tenkan Sisutemu no Donyu ni Kakaru Gyomu* 家畜排せつ物等バイオマスを活用した発電等エネルギー転換システムの導入に係る業務 (Report on energy conversion systems of power generation from livestock manure). Online. <https://www.city.kikuchi.lg.jp/q/aview/165/16020.html> (Accessed February 20, 2020)
- Udert, K. M., Buckley, C. A., Wächter, M., McArdell, C. S., Kohn, T., Strande, L., Zöllig, H., Fumasoli, A., Oberson, A. and Etter, B. 2015. Technologies for the treatment of source-separated urine in the eThekweni Municipality. *Water SA* 41(2): 212–221. <https://doi.org/10.4314/wsa.v41i2.06>
- Wylie, M. J., Fontenot, J. P. and Greene, L. W. 1985. Absorption of Magnesium and Other Macrominerals in Sheep Infused with Potassium in Different Parts of the Digestive Tract. *Journal of Animal Science* 61(5): 1219–1229. <https://doi.org/10.2527/jas1985.6151219x>
- Yakushido, K. 薬師堂謙一 2000. Taihi no Ryutsu-Ka ni tsuite 堆肥の流通化について (Commercialization of compost). *Chikusan Kankyo Joho* 畜産環境情報 8. Online. <https://dl.ndl.go.jp/info:ndljp/pid/9213230?tocOpened=1> (Accessed February 20, 2020)

# Polyethylene Glycol-Coated Magnetic Nanoparticles-Based Draw Solution for Forward Osmosis

Mokhtar GUIZANI<sup>1,2,3</sup>, Takahiro ENDO<sup>3</sup>, Ryusei ITO<sup>1</sup>, Naoyuki FUNAMIZU<sup>4</sup>

<sup>1</sup> Faculty of Engineering, Hokkaido University, Japan

<sup>2</sup> Global Station for Food Land and Water Resources, Global Institution for Collaborative Research and Education, Hokkaido University, Japan

<sup>3</sup> Graduate School of Global Food Resources, Hokkaido University, Japan

<sup>4</sup> Muroran Institute of Technology, Japan

## Abstract

Forward osmosis (FO) is a promising technology for urine volume reduction to ease the recovery of nutrients. Its efficiency is highly dependent on the draw solution. Hence, functionalization of novel draw solutions for forward osmosis (FO) has become a subject of intense investigation. Coated magnetic nanoparticles (MNPs) based solutions offer great potentials for their ability to generate osmotic pressure as well as their easy recovery. Since concentrated urine features high osmotic pressure, we aim to synthesize a high osmotic pressure generating draw solution. Polyethylene glycol (PEG), is an attractive coating agent as aqueous Polyethylene Glycol solutions are known to generate high osmotic Pressure. Moreover, PEG are hydrophilic and expected to have physical aggregation suppression. In this study, we adopted coprecipitation method to synthesize PEG 4000 coated MNPs as draw solution, and studied the influence of the initial coating agent amount and sonication effect on the coating ratio and the osmotic pressure generation of solutions made of the synthesized particles. We found that initial PEG to MNP ratio affects the coating ratio. Indeed, higher coating ratio is obtained with higher initial PEG to MNP ratio. A PEG to MNP ratio of 1 to 4 led to 31% coating ratio. This coating ratio can be slightly increased if the synthesized draw solution is treated with ultrasound for 30 minutes. Water flux data collected from forward osmosis experiment revealed that this novel draw solution generates osmotic pressure. The osmotic pressure obtained from a draw solution containing a given amount of PEG 4000, is larger than the osmotic pressure if the same amount of PEG 4000 is used alone. Fate of the osmotic pressure of the novel draw solution following recycling of the synthesized MNPs is also evaluated. It was found that the drop in osmotic pressure of the regenerated draw solution is insignificant, proving possibility to reuse this draw solution for many cycles.

*Keywords: urine, nutrients, forward osmosis, draw solution, MNPs, PEG 4000*

## Introduction

Urine diverting toilets were proposed to provide safe and affordable sanitation and to facilitate the separation of human waste products for easy resource recovery (Rieck et al. 2012). The urine fraction is a nutrient-rich solution that can be used as a liquid fertilizer (Sene et al. 2012; 2013). However, its large volumes make its transportation to farmland uneconomical (Pahore et al. 2010), making urine volume reduction necessary. However, this process faces not only the challenge of treatment costs but most available volume reduction technologies are energy demanding as well. Hence, forward osmosis (FO)—a naturally occurring phenomenon—has emerged as a promising

low-energy technology for urine volume reduction and resource recovery (Nikiema et al. 2017). The driving force behind FO is the osmotic pressure difference between the feed and draw solutions of different concentrations that are separated by a semi-permeable membrane. Although the operation of FO requires low energy overall, recovery and regeneration of the draw solution requires a high-energy input. Therefore, the choice of draw solution is of the utmost importance. Investigations on novel draw solutions have interested many researchers as exemplified by the works of Guizani et al. (2019), Ge et al. (2011), Yang et al. (2013), Campos et al. (2015), and Ling et al. (2010) among others. Special interest has been given to the functionalization of coated magnetic nanoparticles (MNPs) due to their ease of recovery with a magnet (Ling et al. 2010). The ultimate objective of our research was to synthesize an easy-to-recycle and high osmotic pressure-generating draw solution. It is worth mentioning that urine that has been concentrated 5 folds is characterized by an osmotic pressure exceeding 10 MPa (Nikiema et al. 2017). However, due to their large size, in comparison to the common electrolytes, MNPs do not exhibit high osmotic pressure properties when present in solutions on their own (Guizani et al. 2018). To overcome this limitation, MNPs are coated with osmotic pressure-generating polymeric agents. Researchers have evaluated the usage of different coating materials, such as dextran, oleic acid, polyacrylic acid, and tri-sodium citrate (Zhang 2006; Hong et al. 2009). While many coating agents were tested here, it was possible to suppress aggregation by covering the particle surface with a hydrophilic coating agent to increase the coating ratio and particle concentration. However, the osmotic pressure achieved was low and impractical, and thus, insufficient for concentration of solutions, such as urine or wastewater. Polyethylene glycol (PEG) is an attractive coating agent, owing to the capability of aqueous polyethylene glycol to generate high osmotic pressure (Money 1989). In this study, PEG 4000 (with an average molecular weight of 4000), which is a hydrophilic compound expected to suppress physical aggregation, and thus, generate high osmotic pressure, was used as a coating agent.

Micro-emulsion, thermal decomposition, and chemical coprecipitation are the major common methods used to synthesize iron oxide MNPs (Majidi et al. 2016). Amongst these, thermal decomposition is the most common method for the purpose. It is reported that PEG can synthesize uniform particles of about 10-nm diameter/radius via the thermal decomposition method and generate an osmotic pressure of about 2.8 MPa (Ge et al. 2011). However, this route was recently proven to induce defects and negatively affect the properties of the MNPs. In this study, we adopted the co-precipitation method to synthesize PEG 4000-coated MNPs as a draw solution due to its convenience, simplicity, and low cost; we also studied the influence of the initial amount of coating agent on the coating ratio and the osmotic pressure of a draw solution prepared from the synthesized particles. The fate of the osmotic pressure of the novel draw solution, following recycling of the synthesized MNPs, was also evaluated.

## 1. Material and Methods

### 1.1. Draw solution synthesis

Magnetic nanoparticles were prepared using the co-precipitation technique (Figure 1). Two-hundred millilitres solutions of analytical grade iron chloride (III) · hexahydrate (8.59 g) and iron chloride (II) · tetra-hydrate (23.35 g) were mixed thoroughly. Afterwards, 100 mL of alkaline sodium hydroxide solution (5 M) was added to the blend under conditions of nitrogen gas purging and was kept for an hour in a warm bath (80°C). Upon addition of the alkaline solution, a black precipitate was formed. It has been confirmed in an earlier study (Guizani et al. 2018) that this black precipitate is magnetite ( $\text{Fe}_3\text{O}_4$ ), whose formation takes places through reactions described in equations (1), (2), and (3). As per these chemical equations, a yield of 10 g  $\text{Fe}_3\text{O}_4$  was expected from the aforementioned recipe, which was confirmed experimentally. Following the addition of the aqueous solution of sodium hydroxide and an hour of continuous mixing, 100 mL each of solutions containing 2.5, 5, or 40 g PEG 4000 was added; the

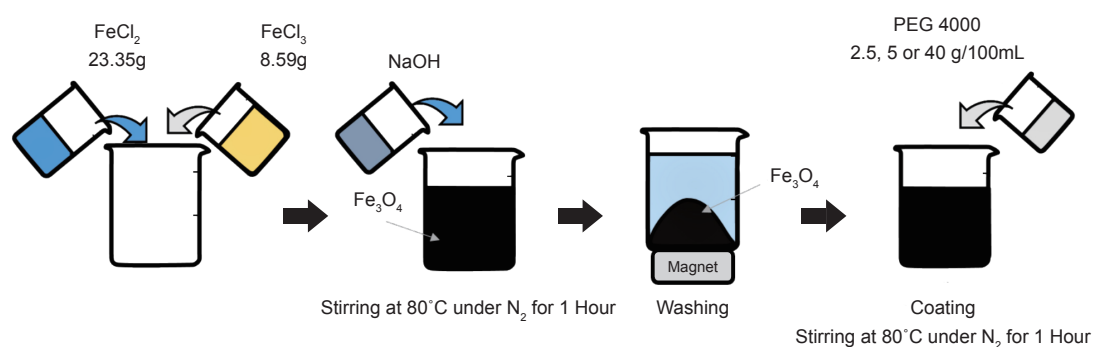

Figure 1. Synthesis of PEG-coated magnetic nanoparticles by the co-precipitation method.

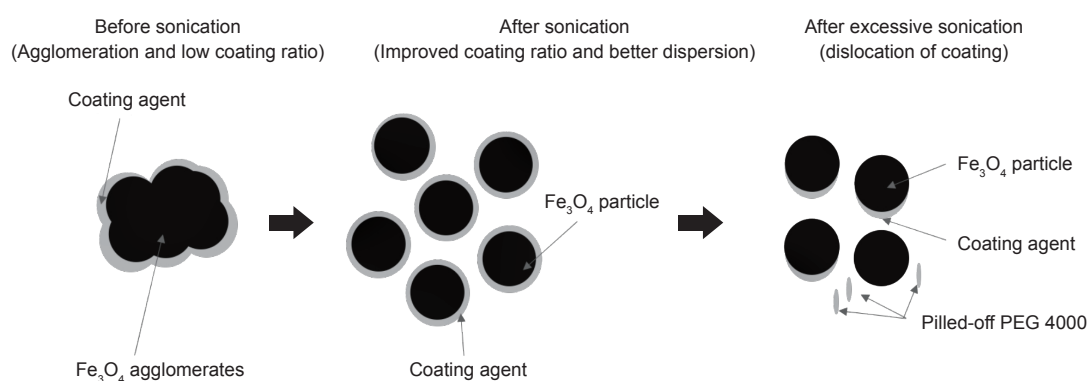
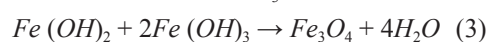

Figure 2. The mechanism of working of the ultrasonic homogenizer (UH 50) used in this study. (Adopted from Guizani et al. 2019)

mixtures thus prepared were stirred at 800 rpm for 1 h at 80°C. These amounts corresponded to the initial MNP to PEG ratios of 1:0.25, 1:0.5, and 1:4. The synthesized particles were washed several times until the pH was approximately 7. A neodymium magnet was used to recover magnetite particles at each washing step.



## 1.2. Assessment of the coating ratio

Coating ratio was determined using the gravimetric method. After the coated MNPs were dried at 105°C; they were then burned at 800°C. The amount of mass reduction with respect to the initial mass of MNPs was taken as the coating ratio.

## 1.3. Ultrasonic treatment

To improve coating ratio, ultrasonication was applied. In an earlier study by Guizani et al. (2019), it was confirmed that the average particle diameter of magnetite decreases by application of ultrasonic treatment. Moreover, the agglomeration of particles during particle recovery using a magnet was confirmed. Therefore, it was expected here that the coating ratio could be increased as a result of increase in surface area. The ultrasonic treatment was carried

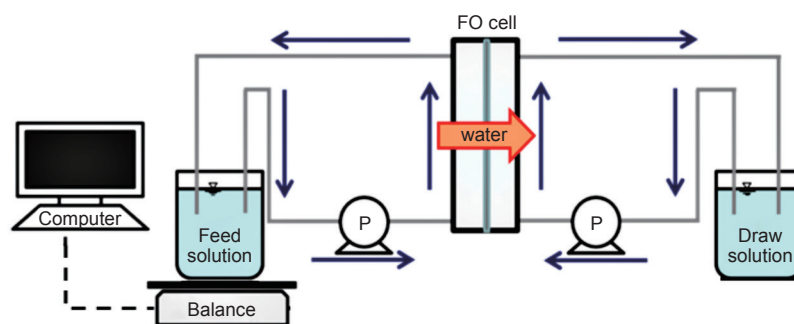

**Figure 3. Forward osmosis experiment**  
(draw solution + magnetic nanoparticles; feed solution deionized water).

**Table 1. Forward osmosis experimental conditions.**

Flow rate	0.20 m/s (co-current)
Operation time	1 h
Membrane	Cellulose triacetate (CTA)
Effective membrane area	98 cm <sup>2</sup>

out using a 20-kHz, 50-watt probe ultrasonic homogenizer, UH 50 (SMT Corporation, Japan). Figure 2 illustrates the working mechanism of sonication and its expected effect on dispersion and coating ratio. The mixture of MNPs and PEG 4000 was sonicated for 30 min and then stirred for another 60 min.

#### 1.4. Synthesis of the draw solution

An FO device with an effective membrane area of 98 cm<sup>2</sup> was used with a cellulose triacetate (CTA) membrane sandwiched between symmetrical flow paths with a width of 1 cm and a height of 0.2 cm (Figure 3). The CTA membrane was purchased from Fluid Technology Solutions (FTS, Inc., Albany, USA). The feed (deionized water) and driving (PEG-coated MNPs) solutions were circulated for an hour in co-current mode at a flow rate of 0.2 m/s using two peristaltic pumps. The objective of this experiment was to assess whether this synthesized solution could be used as a draw solution. In other words, we aimed to know whether this solution would generate an osmotic pressure that would allow water to move across the semi-permeable membrane from the feed solution toward itself. For this purpose, the mass change on the feed side was measured using an electronic balance and the water flux was calculated. Equal volumes of 200 mL each of the draw and feed solutions were used in the experiment. Three different coated MNP-based solutions were used as draw solutions with particle concentrations of 2.9, 4.9, and 9.6 wt.%. The feed solution consisted of deionized water. Details of the operational conditions are presented in Table 1.

#### 1.5. Estimation of differential osmotic pressure

Osmosis is the movement of water from an area of low concentration toward that of high concentration. The higher the osmotic pressure difference is, the higher is the water flux. In our experimental setup, the movement

of water depended on the strength of the osmotic pressure difference between the feed and draw solutions. The osmotic pressure can be calculated from the molar concentration of each solution as given in equation (4).

$$\Delta\pi = iMRT \quad (4)$$

Where  $M$  is the molar concentration of dissolved species ( $\text{mol L}^{-1}$ ),  $R$  is the ideal gas constant ( $0.08206 \text{ L atm mol}^{-1} \text{ K}^{-1}$ ),  $T$  is the temperature (K), and  $i$  is the van't Hoff factor for the solute.

It has been suggested that water flux is linearly proportional to the osmotic pressure difference as given in equation (5).

$$J_w = k\Delta\pi \quad (5)$$

Where  $J_w$  is the water flux ( $\text{L m}^{-2} \text{ h}^{-1}$ ),  $k$  is the water permeability coefficient ( $\text{L m}^{-2} \text{ h}^{-1} \text{ bar}^{-1}$ ), and  $\Delta\pi$  is the osmotic pressure difference (bar).

It is worth mentioning that for each new membrane lot used, the membrane permeability coefficient was determined. An FO experiment was conducted using deionized water as the feed solution and NaCl as the draw solution. Pure water flux was measured during the first 10 min of the operation of FO; its values were plotted against the osmotic pressure applied. The membrane permeability coefficient ( $k$ ) was obtained from the slope of equation (5). Once the permeability coefficient of the membrane was known, the unknown osmotic pressure of a newly tested draw solution could be obtained by dividing the water flux obtained from the FO experiment by the permeability coefficient. However, Wang et al. (2016) have reported that the water fluxes of CTA membranes deviated from the theoretical fluxes obtained from this linear equation. Indeed, concentration polarization makes the flux drop below the theoretical values. At higher osmotic pressure, the concentration polarization is larger, leading to a larger difference from theoretical values. A similar phenomenon was observed by Matsuda (2017) and Nikiema et al. (2017).

For the PEG-coated MNPs, the generation of osmotic pressure in the coated ferromagnetic particles is still not understood well. Therefore, no theoretical equation is available in the literature to mathematically represent the phenomenon. For the sake of simplicity, the differential osmotic pressure has been estimated from the water flux data using the aforementioned linear equation.

## 2. Results and Discussion

### 2.1. Coating ratio

As illustrated in Figure 4, the coating ratio increased as a result of an increase in the amount of the coating agent. The coating ratio increased from 3% to 6% and then to 31%, respectively, for 2.5, 5, and 40 g of PEG 4000. In other words, for 10 g of magnetite, only 0.3, 0.6, and 3 g of PEG 4000 effectively coated the magnetite, respectively.

The work of Guizani et al. (2018) revealed that beyond a certain initial MNP:coating agent ratio, the coating ratio will not be improved, rather it will only decrease. This is attributed to the fact that excessive amounts of coating agent will cause it to peel off from the MNPs leading to a drop in the coating ratio. The results obtained in this paper do not reveal the optimum coating ratio.

As shown in Figure 5, the use of ultrasonic treatment improved the coating ratio. Indeed, an increase of coating ratio from 31% to 40% was achieved. This increase was most likely due to the dispersion of aggregated particles by sonication, which led to a larger surface area being exposed for coating. A detailed study on the effect of the

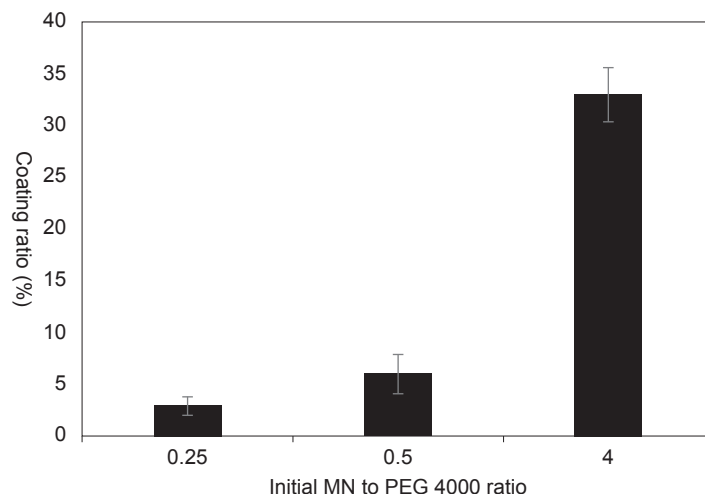

**Figure 4. Effect of initial magnetic nanoparticles to polyethylene glycol 4000 ratio on the coating ratio.** (Error bars show standard deviation (SD))

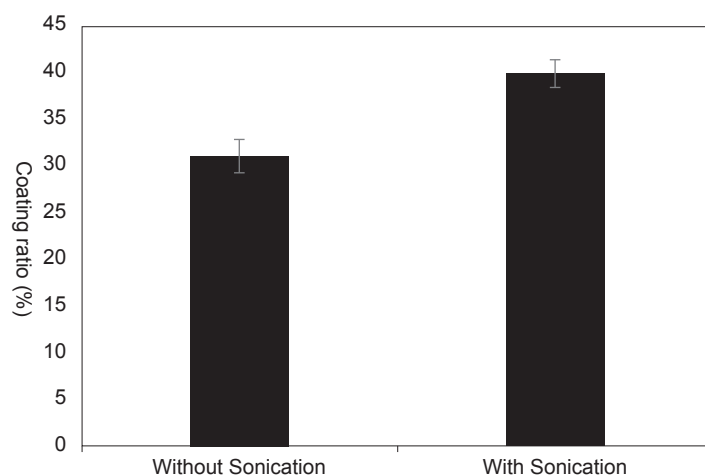

**Figure 5. Effect of sonication on the coating ratio.** (Error bars show standard deviation (SD))

ultrasonic treatment can be found in the work by Guizani et al 2019.

Optimized conditions for synthesis and coating were adopted for the rest of the study. In other words, further experiments were conducted using an initial MNPs to PEG 4000 ratio of 1 to 4. After sonication, the coating ratio was 40%. Solutions containing wt.% of 2.9, 4.9, and 9.6% were prepared for measurement of water flux and estimation of osmotic pressure. The amount of PEG 4000 in the solution was calculated using the 40% coating ratio.

## 2.2. Water flux measurements and estimation of osmotic pressure

Figure 6 illustrates the time course of weight change in the feed tank (feed solution weight). The change reflects the movement of water from the feed to the draw side as the amount of water decreases in the former. The experiment was conducted for an hour, followed by calculation of the water flux. As an example in Figure 6, the water drops from 200 g to 191 g over a one-hour period, providing a flux of one litre per square meter per hour (LMH). Using the permeability constant, differential osmotic pressure was obtained. Matsuda et al. (2017)



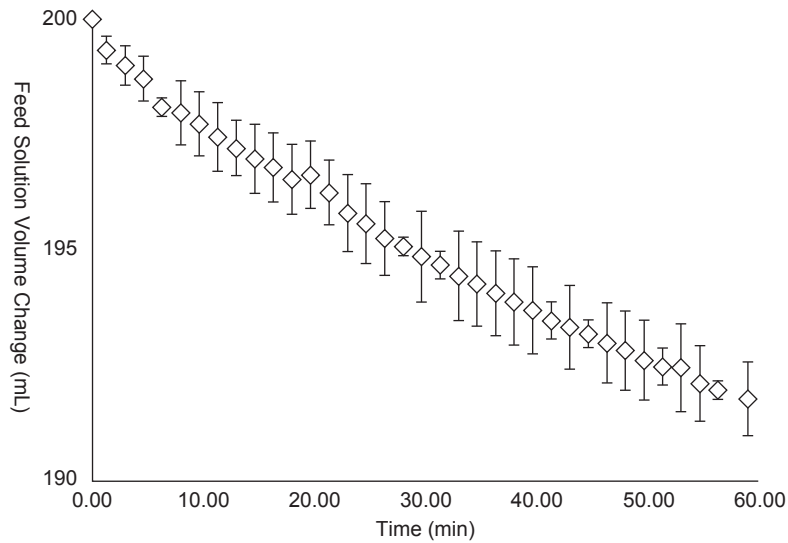

**Figure 6. Time course of weight change in feed solution reservoir: Draw solution composed of coated magnetic nanoparticle solution with particle concentration of 9.6 wt.%. (Error bars show standard deviation (SD))**

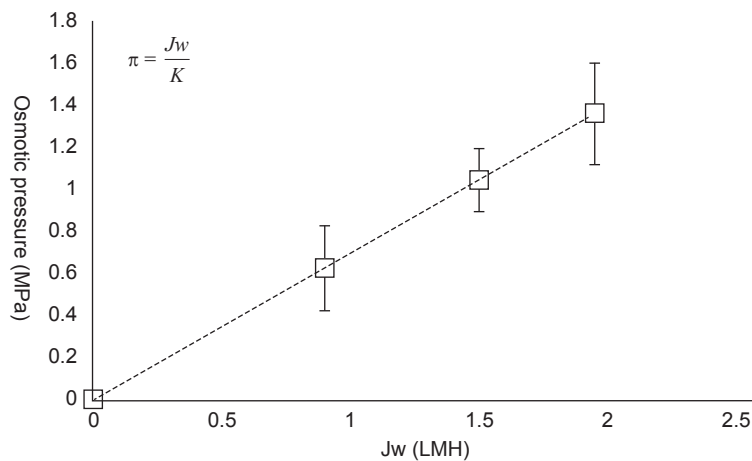
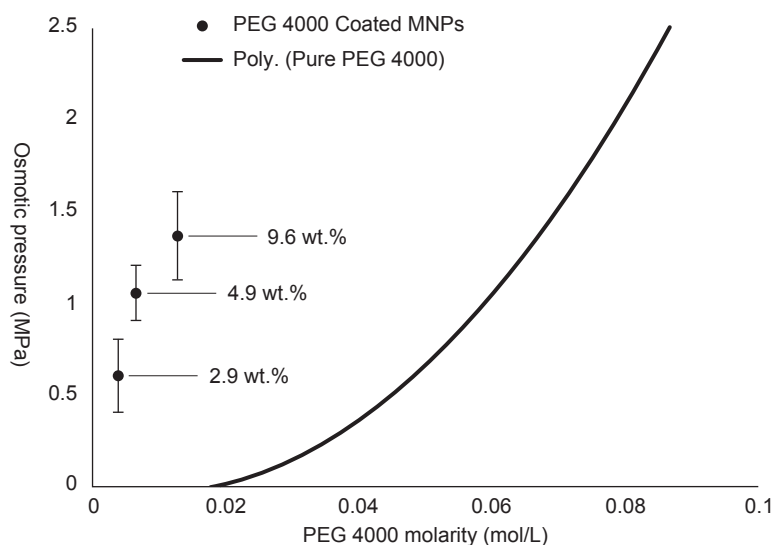

**Figure 7. Estimated osmotic pressure versus water fluxes. (Error bars show standard deviation (SD))**

measured the permeability of the membranes used in this study with the same method described in Section 2.5. The authors reported an average value of  $1.44 \text{ L m}^{-2} \text{ h}^{-1}$  per MPa. Using this permeability value, osmotic pressure ranges were estimated to be 0.6, 1.04, and 1.37 MPa, respectively for 2.9, 4.9, and 9.6% wt.%, respectively (Figure 7). However, as reported by Wang (2015) and Matsuda (2017) for CTA membranes, water flux does not obey the linear relationship due to the polarization of internal concentration. In our study, for a given osmotic pressure, the observed flux was recorded to be much lower than the ones estimated using the linear relationship, i.e. the osmotic pressure estimated using permeability coefficient was underestimated.

### 2.3. Osmotic pressure versus wt.%

In case of an ideal solute, the Van't Hoff's relationship is linear between osmotic pressure and molarity; this



**Figure 8. Relationship between concentration (wt.%) and osmotic pressure for PEG 4000-coated MNPs.**  
(Error bars show standard deviation (SD))

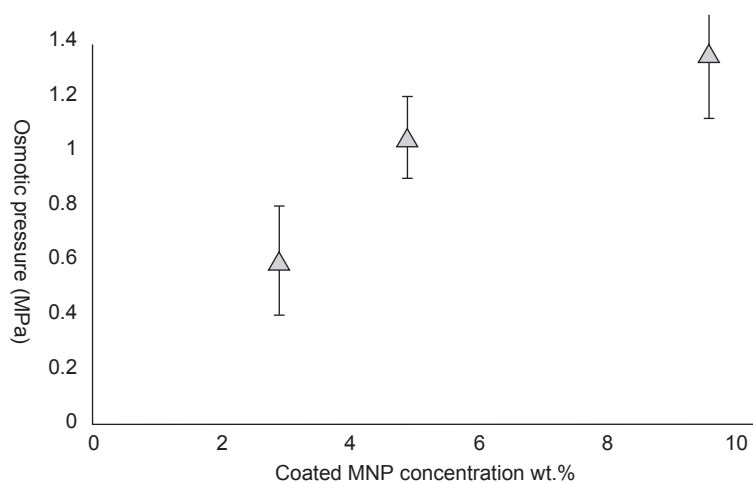

**Figure 9. Relationship between concentration (wt.%) and osmotic pressure for PEG 4000 coated MNPs.**  
(Error bars show standard deviation (SD))

applies to solutions of inorganic salts, such as sodium chloride and potassium chloride. However, polyethylene glycol is reported to not behave as an ideal solute in an aqueous solution. Money (1989) reported that the relationship between concentration and osmotic pressure is not linear, instead it is a second-order polynomial relationship (Figure 8). Steuter et al. (1981) explained this using the fact that, in the case of high-molecular weight solutes, large polymers break into subunits; the higher total number of subunits may then lead to a higher osmotic pressure.

Figure 8 illustrates the osmotic pressure of PEG-coated MNPs and an aqueous solution with PEG 4000 alone. It reveals that PEG 4000-coated MNPs could generate an osmotic pressure of 0.6, 1.05, and 1.37 MPa, respectively, at

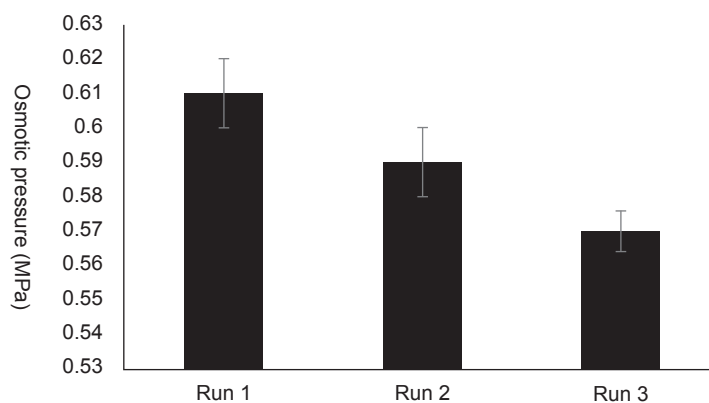

**Figure 10. The osmotic pressure of the regenerated draw solution.**  
(Error bars show standard deviation (SD))

weight concentrations of 2.9, 4.9, and 9.6 wt.%, respectively. It is worth mentioning that at the same concentration levels of PEG, higher osmotic pressure was generated by PEG-coated MNPs, in comparison to the aqueous solution containing PEG only. This could be attributed to the fact that contained electrolytes produce stronger osmotic pressure than free uncontained electrolytes, such as polyelectrolytes contained in ion-exchange resin or in MNPs nano-particles. It is worth mentioning that similar observations were reported by Dey and Izake (2015). These observations led us to conclude that osmotic pressure can be generated under non-colligative conditions too. However, the osmotic pressure generated is not high enough to concentrate urine and recover nutrients. Urine that has been concentrated 5 folds requires a minimum osmotic pressure of 11.62 MPa (Nikiema et al. 2017). It is worth mentioning that osmolality of more than 2.5 osmol/kg has been reported using a 0.087 mol/L poly-acrylic acid solution (Johnson 2017). In addition, in this study, we observed that with the initial ratio of 1:4 of an MNP-coating agent, coating ratio saturation could not be confirmed, which suggested that a higher osmotic pressure could be achieved by increasing the initial amount of coating agent. Furthermore, it is already established that higher molecular weight PEG generates higher osmotic pressure. Therefore, high-molecular weight coating agent, such as PEG 10000, is expected to improve the osmotic pressure of the draw solution. With respect to the agglomeration of particles, performing coprecipitation in the presence of a dispersant is likely to reduce surface tension of the synthesized particles and lead to the formation of smaller particles, and thus, a higher coating ratio, which eventually leads to a higher osmotic pressure.

The relationship between concentration (wt.%) and osmotic pressure for PEG 4000-coated MNPs is illustrated in Figure 9. At higher wt.%, higher osmotic pressure was recorded. Further investigation is required to understand the relationship between osmotic pressure and the concentration of PEG-coated MNP solution.

#### 2.4. Repetitive use of PEG 4000 MNP-based draw solution

Three FO experimental runs were performed, where the draw solution of PEG-coated MNPs was recovered and reused as a regenerated draw solution, assuming no loss of particles had occurred. Figure 10 illustrates the osmotic pressure of the draw solution as calculated from flux at each run. Results show that the osmotic pressure dropped from 0.61 MPa to 0.59 MPa in the second run and to 0.57 MPa in the third run. The loss of osmotic pressure was not significant. Assuming that the drop proceeds linearly, multiple reuses may be possible. We conclude based on our observations that, although there was only a slight drop in the osmotic pressure, repetitive use of the novel draw solution is possible. However, an evaluation of its use for several times is required.

## Conclusion and Recommendations

This study aimed to synthesize a novel draw solution for concentration of urine via the FO process. In this study, we successfully synthesized a novel draw solution made of PEG 4000-coated magnetic nanoparticles. The highest osmotic pressure generated by this novel draw solution was 1.37 MPa. At the same concentration level, PEG 4000 alone generates a lower osmotic pressure. Repetitive use of this novel draw solution revealed that its osmotic pressure drops slightly after each use. Our study helps to solve an important challenge hindering the common use of the FO system. An easy-to-recover draw solution was prepared that was also free of reverse diffusion. However, higher osmotic pressure is needed to concentrate urine. Therefore, although the draw solution cannot be used to concentrate urine in its current form, this study offered a better understanding of its synthesis. Further investigations are needed to obtain a higher osmotic pressure.

## Acknowledgements

Our research activities were supported by “The Sanitation Value Chain: Designing Sanitation Systems as Eco-Community Value System” Project funded by the Research Institute for Humanity and Nature (RIHN, Project No. 14200107). Acknowledgement is also due to the Global Station for Food, Land, and Water Resources (GSF), a project of Global Institution for Collaborative Research and Education at the Hokkaido University, for providing support and partial funding to conduct this research.

## References

- Campos, E. A., Pinto, D. V. B., Oliveira, J. I. S., Mattos, E. D. C. and Dutra, R. C. L. 2015. Synthesis, Characterization and Applications of Iron Oxide Nanoparticles: a Short Review. *Journal of Aerospace Technology and Management* 7(3): 267–276. <http://dx.doi.org/10.5028/jatm.v7i3.471>
- Dey, P. and Izake, E. L. 2015. Magnetic nanoparticles boosting the osmotic efficiency of a polymeric FO draw agent: Effect of polymer conformation. *Desalination* 373: 79–85. <https://doi.org/10.1016/j.desal.2015.07.010>
- Ge, Q., Su, I., Chung, T.-S. and Amy, G. 2011. Hydrophilic superparamagnetic nanoparticles: Synthesis, characterization, and performance in forward osmosis processes. *Industrial & Engineering Chemistry Research* 50: 382–388. <https://doi.org/10.1021/ie101013w>
- Guizani, M., Maeda, T., Ito, R. and Funamizu, N. 2017. *Synthesis of magnetic nanoparticles for urine concentration applications using Forward osmosis process*. Water and Environment Technology Conference, August 27–28, 2017. Sapporo, Japan.
- Guizani, M., Maeda, T., Ito, R. and Funamizu, N. 2018. Synthesis and Characterization of Magnetic Nanoparticles as a Candidate Draw Solution for Forward Osmosis. *Journal of Water and Environment Technology* 16(1): 63–71. <https://doi.org/10.2965/jwet.17-040>
- Guizani, M., Maeda, T., Ito, R. and Funamizu, N. 2019. Engineering of Size-Controlled Magnetic Nanoparticles for use as Draw Solution in Forward Osmosis Process. *Desalination and Water Treatment Journal* 154: 21–29. <https://doi.org/10.5004/dwt.2019.24088>
- Hong, R. R., Li, J. H., Qu, J. M. and Li, H. Z. 2009. Preparation and characterization of magnetite/dextran nanocomposite used as a precursor of magnetic uid. *Chemical Engineering Journal* 150(2–3): 572–580. <https://doi.org/10.1016/j.cej.2009.03.034>
- Johnson, D. J., Suwaileh, W. A., Mohammed, A. and Hilal, N. 2017. Osmotic’s potential: An overview of draw solutes for forward osmosis. *Desalination* 434:100–120. <http://dx.doi.org/10.1016/j.desal.2017.09.017>

- Lefebure, N. 2014. *Performance and Fouling Behaviour of Novel Generations of Osmotic Membranes in Forward Osmosis*. Master's dissertation, Faculty of Bio-science Engineering, Ghent University, Belgium.
- Ling, M. M., Wang, K. Y. and Chung, T. S. 2010. Highly water soluble magnetic nanoparticles as novel draw solutes in forward osmosis for water reuse. *Industrial & Engineering Chemistry Research* 49: 5869–5876. <https://doi.org/10.1021/ie100438x>
- Matsuda, T. 2017. *Concentration of cow urine using forward osmosis*. Master's dissertation, Graduate School of Engineering, Hokkaido University, Sapporo.
- Majidi, S., Sehrig, F. Z., Farkhani, S. M., Goloujeh, M. S. and Akbarzadeh, A. 2016. Current methods for synthesis of magnetic nanoparticles. *Artificial Cells, Nanomedicine, and Biotechnology* 44(2): 722–734. <https://doi.org/10.3109/21691401.2014.982802>
- Money, N. P. 1989. Osmotic Pressure of Aqueous Polyethylene Glycols. *Plant Physiology* 91: 766–769.
- Nikiema, B. C. W.-Y., Ito, R., Guizani, M. and Funamizu, N. 2017. Estimation of Water Flux and Solute Movement during the Concentration Process of Hydrolyzed Urine by Forward Osmosis. *Journal of Water and Environment Technology* 15(5): 163–173. <https://doi.org/10.2965/jwet.16-074>
- Pahore, M. M., Ito, R. and Funamizu, N. 2010. Rational design of an on-site volume reduction system for source-separated urine. *Environmental Technology* 31(4): 399–408.
- Rieck, C., von Münch, E. and Hoffmann, H. 2012. *Technology review of urine-diverting dry toilets (UDDTs): Overview on design, management, maintenance and costs*. Deutsche Gesellschaft fuer Internationale Zusammenarbeit (GIZ) GmbH, Eschborn.
- Sene, M., Hijikata, N., Ushijima K. and Funamizu, N. 2012. Adequate Human urine application pattern for agriculture. *International Research Journal of Agricultural Science and Soil Science* 2(1): 38–45.
- Sene, M., Hijikata, N., Ushijima K. and Funamizu, N. 2013. Effects of extra human urine volume application in plant and soil. *International Research Journal of Agricultural Science and Soil Science* 3(6): 182–191.
- Steuter, A. A., Mozafar, A. and Goodin, J. R. 1981. Water potential of aqueous poly-ethylene glycol. *Plant Physiology* 67(1): 64–67. <https://doi.org/10.1104/pp.67.1.64>
- Wang, Z., Zhen, J., Tang, J., Wang, X. and Wu, Z. 2016. A pilot-scale forward osmosis membrane system for concentrating low strength municipal wastewater: performance and implication, *Scientific Reports* 6, Article number: 21653. <https://doi.org/10.1038/srep21653>
- Yang, H. M., Lee, K. W. and Moon, J. K. 2013. Synthesis of magnetic nanoparticles as a draw solute in forward osmosis membrane process for the treatment of radioactive liquid waste. *Proceedings of the Transactions of the Korean Nuclear Society Spring Meeting*; 229–230.
- Zhang, L., He, R. and Gu, H. C. 2006. Oleic acid coating on the monodisperse magnetite nanoparticles. *Applied Surface Science* 253(5): 2611–2617. <https://doi.org/10.1016/j.apsusc.2006.05.023>



# Knowledge, Attitudes and Practices of Sanitation and Hygiene among Primary School Students in Rural Area of Northeast China

Jiabei HE<sup>1</sup>, Yi ZENG<sup>1</sup>, Ming HAO<sup>1</sup>, Taro YAMAUCHI<sup>1,2</sup>

<sup>1</sup> Graduate School of Health Sciences, Hokkaido University, Japan

<sup>2</sup> Research Institute for Humanity and Nature, Japan

## Abstract

Disease burden due to unsafe water, lack of sanitation, and poor hygiene behavior requires attention. In developing countries, poor school hygiene behavior remains high-risk and causes infectious disease among students. Safe hygiene behavior such as hand washing with soap can protect children from infectious disease. However, a cross-sectional study found the correct rate of hand washing of Chinese people was only 4%. Our research evaluated the knowledge, attitudes, and practices (KAP) of sanitation and hygiene among school children in the rural area of Northeast China. Participants were 333 groups of students and their parents. A questionnaire was used in the participants who reported the score of KAP level of sanitation and hygiene. Hand washing skill was checked following a checklist. Observation of sanitation facilities at school was also conducted. The questionnaires included participant characteristic, household socioeconomic status, and KAP questionnaire. The results of the questionnaires survey showed more than 80% of students had adequate knowledge of proper hygiene. Although students have sufficient knowledge about hygiene, lack of facilities may negatively affect their practice. There was no soap available in 2 schools, 53% of students reported it affects their hand washing performance at school. The results indicated the impact of gender, facilities and knowledge level on behavior. Our findings underscore the need for more hygiene education and the improvement of sanitation and hygiene facilities in the area.

*Keywords: sanitation, hygiene, KAP, child health, hand washing*

## Introduction

Disease burden due to inadequate and unsafe water, lack of sanitation and poor hygiene behavior is a significant issue (Nath 2009). According to the recent estimates, these 3 factors could prevent 58% of diarrheal deaths among children under 5 years of age worldwide per year (WHO et al. 2015). In developing countries, poor school hygiene behavior remains high-risk and causes infectious disease among primary school students (Assefa and Kumie 2014). Intervention studies have suggested that maintaining good hygiene behavior is vital for preventing the diffusion of infectious diseases and reducing the risk of child diarrhea and malnutrition (Aiello and Larson 2002). For example, simple hand washing with soap helps to protect children from diarrhea and lowers respiratory infection (Aiello et al. 2008).

Poor hygiene knowledge and attitudes caused the Chinese citizens' ineffective use of the sanitation facility. Hygiene environment was enhanced in the rural area of China. The coverage of sanitary toilets in the rural area has increased from 7.5% in 1993 to 78.5% in 2015 (NHFPC 2016). However, the proper hand washing rate of Chinese people was only 4% (Tao et al. 2013). According to the Chinese Center for Disease Control and Prevention, in Liaoning Province, 239 cases of infectious disease occurred from 2004 to 2013 were prevalent mostly in primary

school (Xu et al. 2016).

Knowledge and attitudes are some of the measures which are thought to be on the causal pathway to behavior. Inadequate knowledge, attitudes, and practices had negative consequences for a child's hygiene behavior (Scott et al. 2007). Thus, to ensure safe hygiene behavior to be implemented, the proper knowledge and attitudes of hygiene must be taken into account. However, very few studies have assessed the knowledge, attitudes and practices among students towards hygiene behavior in China.

This study examined the current situation of general sanitation and hygiene of children. We identified the knowledge, attitudes and practices (KAP) level of hygiene behavior of primary school students in the rural area of Benxi, Liaoning Province, Northeast China. This study also investigated students' demographics, nutritional status, household socioeconomic status and the status of sanitation environment at school.

## **1. Subjects and Methods**

### **1.1. Research area and subjects**

This study was carried out from September to October 2018, in the rural area of Benxi, Liaoning Province, Northeast China. Data was collected in 2 primary schools. There were 365 students in the 2 schools (211 boys, 154 girls). Children who were over 13 years old and absent during the investigation period were excluded. Children who disapprove this research by their parents were also excluded. The population included 333 healthy primary school students (grades 1–6, 6–13 years old) and their parents (25–57 years old, 331 mothers and 332 fathers). After explaining the purpose of the survey, all students went through the anthropometric measurements, hand washing test, and completed the questionnaires. The purpose of this study was explained to their parents with the parental consent letter. Questionnaires of students and parents were administered.

The data from the 2 schools as mentioned above were combined when summarizing the result and discussion. Considering the service level of water, sanitation and hygiene in each school are clarified at the same level, the same questionnaire and hand washing test were conducted in both schools.

### **1.2. Observation**

Observations were conducted in 2 primary schools. The service level of water, sanitation, and hygiene (WASH) of each school was specified, following the original JMP service ladders for WASH in schools (WHO and UNICEF 2017).

### **1.3. Anthropometric measurements**

The measurement of each item was conducted by the principal author to avoid inter-observer biases. Height was measured to the nearest 0.1cm using a stadiometer (Seca 213; Seca, Germany) and body weight to the nearest 0.1 kg using a digital weight scale (BC-754-WH; Tanita, Japan). Body mass index (BMI; in kg/m<sup>2</sup>) was calculated based on the height and weight measurements. Height-for-age Z-score (HAZ) and body mass index-for-age Z-score (BMIAZ) were calculated based on the WHO AnthroPlus (version 1.0.4) (WHO 2009a). According to recommendations by WHO, children with HAZ < -2 were categorized as stunted, BMIAZ < -2 as thin and BMIAZ > 2 as obese.

### **1.4. Questionnaire survey**

All the questionnaires were made for 2 specific participant groups.

Questionnaire for parents included birth date, educational background, occupation, monthly household income, and the number of family members.



Questionnaire for children included demographics (birth date, gender, grade, the diarrhea symptom during the past 2 weeks) and KAP questionnaire of sanitation and hygiene. Self-reported questionnaires in Chinese were suitable for local contexts. The questionnaire was developed for this study based on various previous studies. Questions were in the quest for following information: drinking water, hand washing habits, waste disposal, and waterborne disease. The scores were calculated based on the correct answers for each question. Question 14, 15 and 16 were excluded. Question 1, 3, 8, 9, 10, 11, and 12 were multiple-choice questions. Higher scores indicate better knowledge, attitudes, and practices level of hygiene behavior.

### 1.5. Hand washing skill test

Hand washing facilities in both schools were in the school toilet (Figure 1). To provide student's privacy, the hand washing skill test was held in a laboratory and a detached room with water taps (Figure 2).

Researchers provided bar soap and tissues for the hand washing test. Children's hand washing skill was examined following a hand washing skill checklist. The checklist for measuring the hand washing skill was modified based on the WHO hand hygiene technique with soap.

The checklist comprises 11 steps, 1) wet hands with water; 2) apply enough soap to cover all hand surfaces; 3) rub hands palm to palm; 4) right palm over left dorsum with interlaced fingers and vice versa; 5) palm to palm with fingers interlaced; 6) backs of fingers to opposing palms with fingers interlocked; 7) rotational rubbing of left thumb clasped in right palm and vice versa; 8) rotational rubbing, backward and forwards with clasped fingers of right hand in left palm and vice versa; 9) rinse hands with water; 10) dry hands thoroughly with a single-use towel; 11) length duration of hand washing. Considering that 40–60 seconds as the duration of the entire hand washing procedure recommends by WHO (2009b). The period more than 40 seconds is defined as eligible. One point for every step, thus the total score is 11. To reduce mistakes and record more details except the checklist, the whole hand washing steps was recorded by a camera and scored based on the recorded video.



Figure 1. Sanitation facilities of each school. (a) (b) School A toilet, (c) (d) School B toilet.  
(Taken by the author)

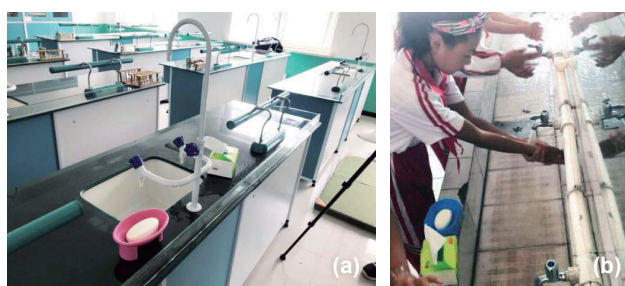

Figure 2. The place of hand wash skill test. (a) School A, (b) School B.  
(Taken by the author)

## 1.6. Statistical analyses

Wilcoxon tests were performed to examine differences in the KAP level among gender and grades. The chi-squared test was performed to examine differences in hand washing skill test between boys and girls. Stepwise variable selection using the increase-and-decrease method was used with a threshold p-value of 0.20, and calculated using a likelihood ratio test. Stepwise regression was performed to examine the factors associated with students' KAP scores. A p-value of  $< 0.05$  was considered statistically significant. JMP 14.1.0 software (SAS Institute Japan, Tokyo, Japan) was used for all statistical analyses.

## 2. Results and Discussion

### 2.1. General status of WASH in research area

Drinking water source and sanitation facilities at 2 schools are safely managed. For the drinking water, there was a hot water supply room at every floor of the teaching building at school A, where students could get boiled water. In school B, students could get water from the drinking water machine with water in tanks at every classroom. Both schools' drinking water was from an improved source, and free from fecal contamination and chemical contamination.

The toilet type was a flush toilet in school A and school B (Figure 1). School A had independent flush toilet. However, school B had only timed water flushing system with tanks. Students cannot flush the toilet immediately after defecation. Toilet at school B did not have doors and provide the privacy.

There were limited numbers of hand washing facilities in both schools. There were 3 sinks with tap water shared by both boys and girls at school A (Figure 3). Toilets for both boys and girls had 1 sink with tap water at school B (Figure 3). Neither school had bar soap or liquid soap. No towels, tissues, nor air driers were provided at school. Only cold water is available all year round.

### 2.2. Characteristics of study participants

Children's characteristics are shown in Table 1. The overwhelming majority of students had correct cognition of hygiene behavior (Figure 4). Despite the fact that there was no significant difference in KAP score by gender. Results of hand washing test showed a significant difference by gender ( $p < 0.05$ ). Boys performed worse than girls in hand washing test. The boys' average score of the hand washing test met only half of the total score.

Table 2 shows the results of child nutritional status. The HAZ of all students ranged from -3.25 to 3.66, and BMIZA ranged from -2.61 to 5.10. The prevalence of stunting, thinness and obesity was 1.5%, 2.7% and 18.9%, respectively. The average BMIAZ was between 0 and 1. It showed that the nutritional status of primary students was generally good. However, the percentage of stunting, thinness, obesity had gender differences, especially obesity in boys may need attention (Figure 2). The obesity prevalence is higher than the nationwide average level. Previous studies reported that the obesity prevalence in China was 14.8% in 2010 (Wang 2009). The averaged BMIAZ of boys was close to 1. Boys also had a higher prevalence of obesity than girls.

The characteristics of parents are shown in Table 3. Almost all the parents participated in the research. There were 20% more fathers engaging in agriculture than mothers (Table 3). Approximately 15% of the mothers had finished senior high school. Compare to the previous study in 85 districts of 10 provinces in China, less mothers finished senior high school in this study (Ji et al. 2018).



Figure 3. Hygiene facilities of each school. (Taken by the author)

(a) School A hand washing facility were out of the toilet, 3 sinks were between men's and women's toilet.

(b) School B hand washing facility were in the toilet and one sink for each toilet.

Table 1. Characteristics of primary school students (n = 333).

Characteristics	n	%
Gender		
Boy	194	58.3
Girl	139	41.7
Diarrhea symptoms <sup>†</sup>		
Reported	53	15.9
Not reported	280	84.1
Age		
6	18	5.4
7	37	11.1
8	54	16.2
9	51	15.3
10	64	19.2
11	62	18.6
12	45	13.5
13	2	0.6
		(mean ± SD)
KAP <sup>‡</sup> questionnaire total score (range) (7–26)		16.61 ± 4.05
Boy		16.44 ± 4.24
Girl		16.83 ± 3.78
Hand wash skill test total score <sup>#</sup> (range) (1–11)		6.38 ± 1.85
Boy		5.93 ± 1.67
Girl		7.03 ± 1.91

<sup>†</sup>Two-week period prevalence.

<sup>‡</sup>Knowledge, Attitudes and Practices (KAP).

<sup>#</sup>Wilcoxon test,  $p < 0.001$ .

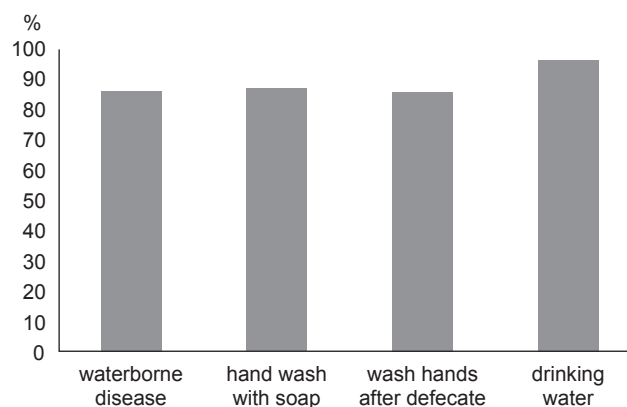

Figure 4. The correct responding rate of knowledge on hygiene (n = 333).

**Table 2. Child nutritional status by gender (n = 333).**

	Boy	Girl
BMI <sub>AZ</sub> <sup>†</sup> (mean ± SD)	0.76 ± 1.57	0.17 ± 1.27
HAZ <sup>‡</sup> (mean ± SD)	0.43 ± 1.06	0.27 ± 1.18
Stunting (%)	1.03	2.16
Thinness (%)	3.09	2.16
Obesity (%)	25.26	10.07

<sup>†</sup>Body mass index-for-age Z-scores (BMI<sub>AZ</sub>).

<sup>‡</sup>Height-for-age Z-scores (HAZ).

**Table 3. Characteristics of household and parents (n = 333).**

Characteristics	n <sup>†</sup>	%
Mother Education background	331	
Completed primary education	74	22.4
Completed middle education	210	63.4
Completed senior education	47	14.2
Mother Occupation		
Agriculture	241	72.9
Non-agriculture <sup>‡</sup>	90	27.1
Father Education background	332	
Completed primary education	62	18.7
Completed middle education	217	65.4
Completed senior education	53	15.9
Father Occupation		
Agriculture	175	52.6
Non-agriculture <sup>‡</sup>	158	47.4
Family monthly income (CNY)		
≤ 1500	59	17.7
1501–3500	147	44.2
> 3500	127	38.1

<sup>†</sup>Missing data excluded.

<sup>‡</sup>Government officials, employee and self-employed.

### 2.3. Knowledge, attitudes and practices level of hygiene behavior among students

#### Water borne disease, waste disposal and drinking water

The results indicated that knowledge about the waterborne disease was uneven in the research area. More than half of the students knew that diarrhea is a waterborne disease, only less than 15% of the students had knowledge about fever (Figure 5). The results was in line with a study in Vietnam, the waterborne diseases that was recount by children were: diarrhea (62%), parasitic diseases (18.6%), skin diseases (17.6%), eye diseases (11%) and gynecological and obstetrical diseases (3.8%) (Sibiya and Gumbo 2013).

Regardless of the fact that the students did not have comprehensive knowledge of waterborne disease, they did better in practices. Most students knew how to prevent water diseases (Figure 4). The students mentioned must be boiled before drinking to avoid waterborne diseases. When asked what respondents could do to prevent diarrhea, “drinking safe water” was the most popular response, and “eating safe food” was the second most prevalent. 88% of students reported that they drink boiled water at school (data not shown).

The study revealed that most of the students obtained information about hygiene from school, television, and internet (Figure 6). This result is due to that students may spend most of their time at school. When they

reach home, they may spend most of their time watching television. The results in line with the study of the urban area in South Africa, school and television are proven to be the most popular sources of information. There were disparities between China and South Africa, with rural schools in South Africa obtaining most of their information from newspapers (Sibiya and Gumbo 2013). The penetration rates of internet and mobile phone in both countries had obvious difference between China and South Africa. According to the report from China Internet Network Information Center (CINIC), the internet penetration rate was high in China. The number of mobile internet users in China reached 871 million, and the proportion of internet users accessing the internet through mobile phones was 98.6% (CINIC 2019). Based on Stats SA's estimate, South Africa reached 40% internet penetration mark in 2017 (WWW 2017). The difference in sources information between the rural area of China and South Africa may relate to the economic development of both countries. South Africa's economy has entered recession and the downturn was driven by contractions in agriculture and manufacturing industries (Anonymous 2018). However, China's GDP increased by 6.6% year-on-year in 2018 to about 90.03 trillion yuan (NBS 2018).

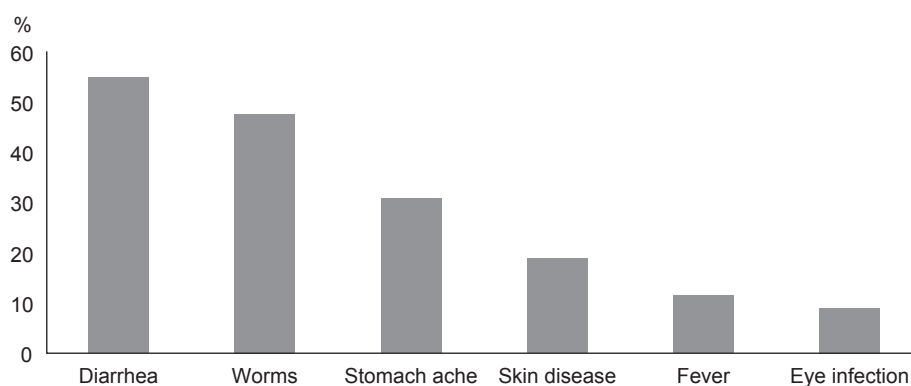

Figure 5. The correct responding rate of each waterborne disease (n = 333).

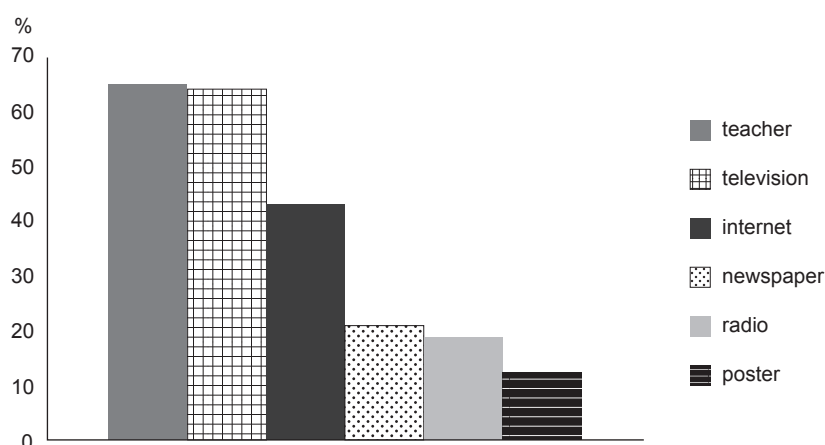

Figure 6. The different sources of information on sanitation and hygiene (n = 333).

### Hand washing habits

Hand washing test in the study also revealed that wash hands with soap is a common behavior of students in the research area if the soap was available. Step 2 of hand washing test examined using enough soap to cover all hand surfaces. The rate of completing the hand washing step 2 was more than 90% (Figure 8). However, neither 2 schools provided bar soap or liquid soap in toilet. Limited hygiene facility is a common situation in the rural areas of developing countries. Research among Colombian school children reported that only 7% of students answered that there is soap regularly available at school (Lopez-Quintero et al. 2009). A UNICEF study in Ethiopia found that only 5% of schools had hand washing facilities. Although students had proper knowledge of hand washing, lack of the facilities may negatively affect proper hand washing knowledge. In our research, most students mentioned the importance of hand washing, indicating a high level of knowledge. The questionnaire survey indicated that 86% of students thought that washing hands with soap is one of the most effective ways to prevent waterborne disease (Figure 4). Question 16 asked students “If you have any difficulty on hand washing at school, what is the reason?”, 53% of students that reported no soap affected their hand washing performance at school (Figure 7). Therefore, they could not practice the hand washing knowledge they had acquired.

Figure 8 indicates the rate of completing the hand washing step of students. Focusing on each step, 92.5% of students used soap, and more than half students dried hands thoroughly with tissue. The result showed that students tend to use tools for hand washing when available. Most children were relatively able to do step 1, 2, 3, 9, and 10. However, each step was not equally performance. In this regard, none of the children perfectly did all 10 steps. Half of the students did step 4, 11.4% did step 7, and few students did step 8. Primary school children were unable to complete all steps based on following 2 reasons. As the WHO checklist procedure is aimed for use in healthcare facilities, it is too detailed for primary school children to achieve at their level fully. This may also imply that students had not received proper hand washing education.

Table 4 presents the results of the stepwise regression. Being a male child and a younger child was associated with a decrease in the KAP scores. In analyzing the parents' background, a child with higher educated mother or whose father's occupation was non-agriculture were more likely to have higher KAP scores. The results indicated that there were significant relationships between the KAP of students with the parents' educational level and occupation.

The results indicated that gender differences could influence washing hands. The rate of completing the hand wash step was lower in boys than girls, which indicated a significant association between gender and hand wash behavior (Figure 8). The results are in line with previous studies, one study reported that females have better hygiene than males in general population (Cruz et al. 2015). It is in agreement with the previous report that female had more positive attitudes toward hand hygiene than male (Sibiya and Gumbo 2013). In our research, we divided students by gender during the hand washing test. Based on the video content of the hand wash test, we found that the girls kept hygiene facilities cleaner than boys. Some boys did not have proper hand washing behavior. They forgot to turn off the tap, wiped hands on their clothes, and threw away tissues. The researcher had to interrupt the hand washing test because some boys throw away tissues which blocked the drain. The impact of gender differences on the hand washing behavior may be due to physical environment. In previous research, the hand washing facilities' cleanliness was strongly associated with hand washing for both genders. In the previous study, 87% of students do not wash their hands after defecation when the washbasins are “dirty”, compared with 36% of those in moderately clean facilities and more 69% in sanitary facilities (Curtis 2003). This study content showed that the girls always kept the physical environment clean, which caused them to keep a better hygiene behavior.

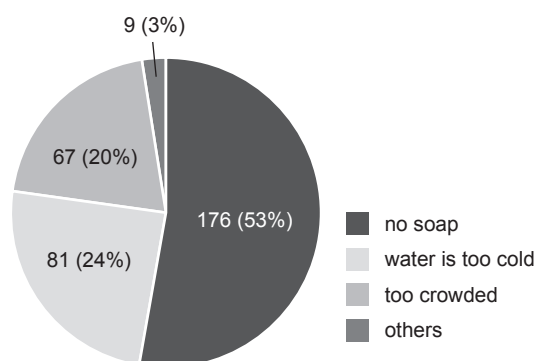

Figure 7. The most important difficulty on hand washing at school among students (n = 333).

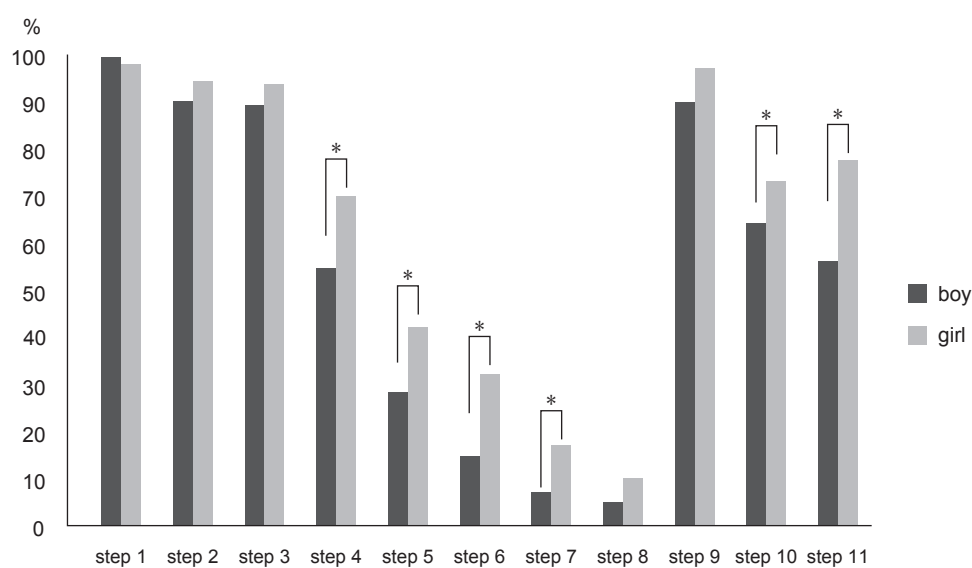

Figure 8. Rate of complete the hand washing step (n = 333).

\*Chi-squared Test,  $p < 0.05$ .

Table 4. Factor associated with students' KAP scores in stepwise regression analysis (n = 333).

	$\beta$	t	VIF	p
Student's gender <sup>†</sup>	0.32	6.36	1.02	< 0.01
Student's age	0.29	5.64	1.06	< 0.01
Mother education level	0.17	3.27	1.03	< 0.01
Father occupation <sup>‡</sup>	0.15	2.6	1.41	< 0.05
Mother occupation <sup>‡</sup>				NS

$R^2 = 0.23$ ; Root meansquare error = 1.64.

<sup>†</sup>Boy = 0, Girl = 1.

<sup>‡</sup>Parents' occupation was divided in to Agriculture and Nonagriculture. Agriculture = 0, Nonagriculture = 1. Nonagriculture included government officials, employee and self-employed.

## Summary

This study revealed the general status of water, sanitation, and hygiene in this area, drinking water source and sanitation facilities of primary school in this research area were safely managed, but hand washing facilities like taps, sinks and soap were inadequate.

In general, the nutritional status of children was found to be acceptable because the average BMIAZ of all students was between 0 and 1. However, the obesity issue in boys needs more attention continuously. The obesity prevalence was higher in boys than girls. Overall, boys were more likely to have a high BMI than girls.

For the knowledge, attitudes, and practices of hygiene research, most of the participants were found to have a correct understanding of those questions. However, only the knowledge of the waterborne disease found to be inadequate. Although students knew little on specific waterborne disease, they had high scores in the practices of this part. Several limitations are considered in the questionnaire survey. Students' self-reported questionnaire may have resulted in over-reporting of proper hygiene practices. In future studies, researchers should attempt to mitigate this limitation by including objective methods examined students' hygiene behavior.

This study also detected the impact of gender, sanitation facilities and knowledge level on hygiene behavior. Although participants had sufficient knowledge of hygiene, a lack of hand washing facilities may negatively affect proper hygiene practices. Students had excellent completion rate in hand washing step1–3. However, we found a gradual decline in the completion rate of the following step. It was caused by the students had not received the proper education of hygiene and hand washing skill. Cleanliness of the physical environment was associated with hand washing practices for both boys and girls. Overall, girls have a better sense of hygiene behavior and keep cleaner environment than boys.

## Acknowledgments

The authors would like to express their sincere gratitude to all participants to the study. The final draft of the article was originated on the very helpful comments made by Dr. A. Sai and all the members of the Laboratory of Human Ecology, Faculty of Health Sciences, Hokkaido University.

## References

- Aiello, A. E. and Larson, E. L. 2002. What is the evidence for a causal link between hygiene and infections? *The Lancet Infectious diseases* 2(2): 103–110. [https://doi.org/10.1016/S1473-3099\(02\)00184-6](https://doi.org/10.1016/S1473-3099(02)00184-6)
- Aiello, A. E., Coulborn, R. M., Perez, V. and Larson, E. L. 2008. Effect of hand hygiene on infectious disease risk in the community setting: a meta-analysis. *American Journal of Public Health* 98(8): 1372–1381. <https://doi.org/10.2105/AJPH.2007.124610>
- Anonymous 2018. South Africa: Economy Slips into Technical Recession. *Africa Research Bulletin: Economic, Financial and Technical Series* 55(8): 22249B–22250C. <https://doi.org/10.1111/j.1467-6346.2018.08504.x>
- Assefa, M. and Kumie, A. 2014. Assessment of factors influencing hygiene behavior among school children in Mereb-Leke District, Northern Ethiopia: a cross-sectional study. *BMC Public Health* 14: 1000. <https://doi.org/10.1186/1471-2458-14-1000>
- Cruz, J. P., Cruz, C. P. and Al-Otaibi, A. S. D. 2015. Gender differences in hand hygiene among Saudi nursing students. *International Journal of Infection Control* 11(4): 1–13. <https://doi.org/10.3396/ijic.v11i4.14123>
- Curtis, V. 2003. Talking dirty: how to save a million lives. *International Journal of Environmental Health Research* 13: S73–S79. <https://doi.org/10.1080/0960312031000102822>



- CNNIC (China Internet Network Information Center) 2019. *The 43rd China Statistical Report on internet Development*. CNNIC, Beijing.
- Ji, D., Chen, H., Chao, M. and Li, X. 季冬, 陈虹, 钞森, 李新影 2018. Jiating Fenwei Yu Fumu Shoujiaoyuchengdu Du Qingshaonian Yiyu Yingxiang 家庭氛围与父母受教育程度对青少年抑郁影响 (Effect of family atmosphere and parental education level on depression among adolescents). *Zhongguo Gonggong Weisheng* 中国公共卫生 34(1): 38–41. <https://doi.org/10.11847/zgggws1113311>
- Lopez-Quintero, C., Freeman, P. and Neumark, Y. 2009. Hand washing among school children in Bogota, Colombia. *American Journal of Public Health* 99(1): 94–101. <https://doi.org/10.2105/AJPH.2007.129759>
- Ma, X., Shi, H., Li, M., Zhang, Z., Hu, Y. and Guo, J. 马雪梅, 史慧静, 李梦娜, 张喆, 胡月明, 郭锦萍 2017. Woguo Jinchengwugong Renyuan Suiqian Zinu Xiaoxuesheng Zhengquexishou Xingwei Ji Jiatingyinxiang Yinsufenxi 我国进城务工人员随迁子女小学生正确洗手行为及家庭影响因素分析 (Analysis of correct handwashing behaviour and related family factors among Chinese urban migrant primary school students). *Zhongguo Xuexiao Weisheng* 中国学校卫生 38(7): 975–979. <https://doi.org/10.16835/j.cnki.1000-9817.2017.07.005>
- Nath, K. J. 2009. Impact of Inadequate Sanitation and Poor Level of Hygiene Perception and Practices on Community Health. *International Academy of Environmental Sanitation and Public Health*, New Delhi.
- NHFPCC (National Health and Family Planning Commission) 国家卫生和计划生育委员会 2016. *Zhongguo Weisheng He Jihua Shengyu Tongji Nianjian* 中国卫生和计划生育统计年鉴 (China Health and Family Planning Statistical Yearbook). Zhongguo Xiehe Yike Daxue Chubanshe, Beijing.
- NBS (National Bureau of Statistics) 2018. *A look at China's economy in 2018*. The State Council of the People's Republic of China. Online. [http://english.www.gov.cn/policies/infographics/2019/01/24/content\\_281476492983178.htm](http://english.www.gov.cn/policies/infographics/2019/01/24/content_281476492983178.htm) (Accessed September 1, 2019).
- Otsuka, Y., Agestika, L., Sintawardani, N. and Yamauchi, T. 2019. Risk Factors for Undernutrition and Diarrhea Prevalence in an Urban Slum in Indonesia: Focus on Water, Sanitation, and Hygiene. *American Journal of Tropical Medicine and Hygiene* 100(3): 727–732. <https://doi.org/10.4269/ajtmh.18-0063>
- Sibiya, J. and Gumbo, J. 2013. Knowledge, attitude and practices (KAP) survey on water, sanitation and hygiene in selected schools in Vhembe District, Limpopo, South Africa. *International Journal of Environmental Research and Public Health* 10(6): 2282–2295. <https://doi.org/10.3390/ijerph10062282>
- Scott, B., Curtis, V., Rabie, T. and Garbrah Aidoo, N. 2007. Health in our hands, but not in our heads: understanding hygiene motivation in Ghana. *Health Policy and Planning* 22(4): 225–233. <https://doi.org/10.1093/heapol/czm016>
- Tao, S. Y., Cheng, Y. L., Lu, Y., Hu, Y. H. and Chen, D. F. 2013. Hand washing behaviour among Chinese adults: a cross-sectional study in five provinces. *Public Health* 127(7): 620–628. <http://dx.doi.org/10.1016/j.puhe.2013.03.005>
- Vivas, A., Gelaye, B., Aboset, N., Kumie, A., Berhane, Y. and Williams, M. A. 2010. Knowledge, attitudes, and practices (KAP) of hygiene among school children in Angolela, Ethiopia. *Journal of Preventive Medicine and Hygiene* 51(2): 73.
- WHO (World Health Organization) 2009a. *WHO AnthroPlus for personal computers Manual: Software for assessing growth of the world's children and adolescents*. WHO, Geneva.
- 2009b. *WHO Guidelines on hand hygiene in health care*. WHO, Geneva.
- 2010. *Nutrition Landscape Information System (NLIS) country profile indicators: Interpretation guide*. WHO, Geneva.
- WHO (World Health Organization) and UNICEF (United Nations International Children's Education Fund) 2017. *Progress on Drinking Water, Sanitation and Hygiene: 2017 Update and SDG Baselines*. UNICEF and WHO, Geneva.
- WHO (World Health Organization), UNICEF (United Nations Children's Fund) and USAID (United States Agency for International Development) 2015. *Improving Nutrition Outcomes with Better Water, Sanitation and*

*Hygiene*. WHO, Geneva.

- Wang, X., Höjer, B., Guo, S., Luo, S., Zhou, W. and Wang, Y. 2009. Stunting and ‘overweight’ in the WHO Child Growth Standards: malnutrition among children in a poor area of China. *Public Health Nutrition* 12(11): 1991–1998. <https://doi.org/10.1017/S1368980009990796>
- WWW (World Wide Worx) 2017. *Internet Access in South Africa 2017 Executive Summary*. WWW. Online. <http://www.worldwideworx.com/internet2017/> (Accessed September 17, 2019).
- Xu, J., Xie T. and Yao W. 许晶瑶, 谢韬, 姚文清 2016. 2004–2013 Nian Liaoning Sheng Tufa Gonggong Weisheng Shijian Liuxingbingxue Tezheng Fenxi 2004–2013年辽宁省突发公共卫生事件流行病学特征分析 (Epidemic Characteristics of Public Health Emergencies in Liaoning Province, 2004–2013). *Yufang Yixue Qingbao Zazhi* 预防医学情报杂志 32(2): 173–176.
- Zhang, Q., Dong, Y., Sun, S., Yuan, H. and Yu, G. 张琴, 董玉婷, 孙思飞, 袁红, 于广军 2017. Yijiaojiehe Dui Sannianjixiaoxuesheng Xishou Zhishi Xingwei Ganyu Xiaoguo Pingu 医教结合对三年级小学生洗手知识行为干预效果评估 (Evaluation of effect of combining medical treatments with education on hand washing knowledge and behavior among primary school students). *Zhongguo Xuexiao Weisheng* 中国学校卫生 38(7): 1007–1009, 1014. <https://doi.org/10.16835/j.cnki.1000-9817.2017.07.014>